

BIDDING DOCUMENTS

PROJECT: PAVING OF HAMBY RD:
US 20 TO BUTLER MARKET RD

PROJECT #: W66116

BID OPENING: JUNE 1, 2022

COMPLETION DATE: SEPTEMBER 2, 2022

CONTRACTING AGENCY:



**ROAD
DEPARTMENT**

**61150 SE 27TH STREET
BEND, OREGON 97702
PHONE: (541) 388-6581
FAX: (541) 388-2719
WEB: www.deschutescounty.gov/road**



ROAD DEPARTMENT

BIDDING DOCUMENTS

PAVING OF HAMBY RD: US 20 TO BUTLER MARKET RD

TABLE OF CONTENTS

INVITATION TO BID.....A1

INFORMATION FOR BIDDERS.....A2

BID PROPOSAL FORM.....B1

SCHEDULE OF BID ITEMS.....B3

SUBCONTRACTOR DISCLOSURE FORM.....B4

BID GUARANTY FORM.....B5

CONTRACT AGREEMENT FORM (FOR INFORMATION ONLY).....C1

PERFORMANCE BOND FORM (FOR INFORMATION ONLY).....C3

PAYMENT BOND FORM (FOR INFORMATION ONLY).....C5

SPECIAL PROVISIONS.....SP1

PROJECT PLANS & OREGON STANDARD DRAWINGS

DESCRIPTION OF PARTS OF BIDDING DOCUMENTS WHICH ARE NOT BOUND HEREIN:

OREGON STANDARD SPECIFICATIONS FOR CONSTRUCTION, 2021

The Specification that is applicable to the Work on this Project is the 2021 edition of the "Oregon Standard Specifications for Construction". All number references in these Special Provisions shall be understood to refer to the Sections and subsections of the Standard Specifications bearing like numbers and to Sections and subsections contained in these Special Provisions in their entirety.

**DESCHUTES COUNTY, OREGON
ROAD DEPARTMENT
INVITATION TO BID
PAVING OF HAMBY RD: US 20 TO BUTLER MARKET RD**

Sealed bids will be received at the Deschutes County Road Department, 61150 SE 27th Street, Bend, Oregon 97702, until but not after, **2:00 p.m. on June 1, 2022**, at which time and place all bids for the above-entitled public works project will be publicly opened and read aloud.

The Class of Work of this Project is Asphalt Concrete Paving and Oiling. The value for this Contract is estimated to be between \$600,000 and \$900,000. The Work will consists of, but not be limited to, the following:

- Install and maintain temporary traffic control.
- Perform asphalt concrete pavement repair.
- Perform cold plane pavement removal on roadway and approaches, as appropriate.
- Construct new asphalt concrete pavement.
- Adjust existing water valve and monument boxes.
- Place aggregate shoulders, as appropriate.
- Install recessed pavement markers and permanent pavement markings.
- Perform additional and incidental work as called for by the specifications and plans.

Specifications and other bid documents may be inspected and obtained from the Deschutes County Bids and RFPs website at <http://www.deschutes.org/rfps>. Inquiries pertaining to these specifications shall be directed to Cody Smith, County Engineer, in writing at Cody.Smith@deschutes.org or the address above.

Bids shall be made on the forms furnished by the County, including a Bid Bond or Cashiers Check for the minimum amount of 10% of the Bid Price, addressed and mailed or delivered to Chris Doty, Department Director, 61150 SE 27th Street, Bend, Oregon 97702 in a sealed envelope plainly marked "BID FOR PAVING OF HAMBY RD: US 20 TO BUTLER MARKET RD" and the name and address of the bidder.

Bidders must submit a Subcontractor Disclosure Statement. The subcontractor disclosure statement may be submitted in the sealed bid prior to 2:00 p.m. on June 1, 2022 or in a separate sealed envelope marked "SUBCONTRACTOR DISCLOSURE STATEMENT - PAVING OF HAMBY RD: US 20 TO BUTLER MARKET RD" prior to 4:00 p.m. on June 1, 2022 at the above location.

Because the work called for under this contract is for a public works project subject to state prevailing rates of wage under ORS 279C.800 to 279C.870, the County will not receive or consider a bid unless the bid contains a statement by the bidder that the bidder will comply with ORS 279C.840. Each bid must contain a statement as to whether the bidder is a resident bidder, as defined in ORS 279A.120. Vendors shall use recyclable and/or sustainably sourced products to the maximum extent economically feasible in the performance of the contract work set forth in this document.

Bidders shall be prequalified with the State of Oregon for the Class of Work stated above in accordance with ORS 279C.430 through 279C.450 and Deschutes County Code 12.52.020. The successful bidders and subcontractors providing labor shall maintain a qualified drug testing program for the duration of the contract. Bidders shall be licensed with the Construction Contractor's Board. Contractors and subcontractors need not be licensed under ORS 468A.720.

Deschutes County may reject any bid not in compliance with all prescribed bidding procedures and requirements, and may reject for good cause any or all bids upon a finding of Deschutes County it is in the public interest to do so. The protest period for this procurement is seven (7) calendar days.

CHRIS DOTY
Road Department Director

PUBLISHED:
DAILY JOURNAL OF COMMERCE: May 18, 2022
THE BEND BULLETIN: May 18, 2022

INFORMATION FOR BIDDERS

1. **General Description of Project.** A general description of the work to be performed is contained in the Invitation to Bid. The scope is indicated in the applicable parts of these Contract documents.
2. **Contract Documents.** The Contract documents under which it is proposed to execute the work consist of the material bound herewith. These Contract documents are intended to be mutually complementary and to provide all details reasonably required for the execution of the proposed work.

Any person contemplating the submission of a proposal and being in doubt as to the meaning or intent of said contract document shall at once notify, in writing, the Road Department Director of Deschutes County, Oregon. Any interpretation of change will be mailed or delivered to each person receiving a set of documents.

3. **Form of Proposals.** All proposals must be submitted on the forms furnished. Subcontractor disclosure form may be submitted with the bid or in a separate envelope.
4. **Substitutions.** Materials and/or products called for in the specifications are named in order to establish a standard of quality design. Manufacturers or suppliers of products similar to those specified may submit bids on the work providing requests for approval of substitution materials are made at least seven (7) calendar days prior to the bid opening. Adequate information on which to base approval or disapproval must be furnished to the Road Department Director or his representative and the Road Department Director shall be the sole judge of any request. When the Road Department Director approves a substitution, it is with the understanding that the Contractor guarantees the substituted article or materials to be equal or better than the specified.
5. **Preparation of Proposals.** All blank spaces in the proposal form must be filled in, in ink, or typed, in both words and figures where required. No changes shall be made in phraseology of the forms. Written amount shall govern in cases of discrepancy between the amount stated in writing and amount stated in figures.

Any proposal shall be deemed informal which contains omissions, erasures, alterations, or additions of any kind, or prices uncalled for, or which, in any manner shall fail to conform to the conditions of the published invitation to bidders.

The bidder shall sign his/her proposal in the blank space provided therefore. Proposals made by corporations or partnerships shall contain names and addresses of the principal officers or partners therein. If a corporation makes a proposal, it must be signed by one of the principal officers thereof, and the corporate seal affixed.

If made by a partnership, it must be signed by one of the partners, clearly indicating that he is signing as a partner of the firm. In the case of a proposal

made by a joint venture, each of the joint venturers must sign the proposal in his personal capacity.

The wording of the proposal shall not be changed. Any additions, conditions, limitations or provisions inserted by the bidder will render the proposal irregular and may cause its rejection.

6. **Submission of Proposals.** All proposals must be submitted in the time and place and in the manner prescribed in the invitation to bid. Proposals must be made on the prescribed proposal forms furnished. Each proposal must be submitted in a sealed envelope, so marked as to indicate its contents without being opened. If the proposal is submitted by mail, the sealed envelope containing the bid must be enclosed in a separate envelope plainly addressed for mailing to conformance with instructions in the Invitation to Bid

A responsive bid proposal must include the following completed items:

- Bid Proposal Form
- Schedule of Bid Items
- Bid Guaranty Form

7. **Modification or Withdrawal of Proposal.** Any bidder may modify his bid by written or telegraphic communication at any time prior to the scheduled closing time for receipt of bids, provided such communication is received by the County prior to the closing time, and provided further that a written confirmation of a telegraphic modification over the signature of the bidder was mailed prior to the closing time. If written confirmation of a telegraphic communication is not received within at least two calendar days of the closing time, no consideration will be given to the modification. The written or telegraphic communication should not reveal the bid price, but should state the addition or subtraction or other modification so that the County will not know the final prices or terms until the sealed bid is opened.

Proposals may be withdrawn prior to the scheduled time for the opening of the proposals either by telegraphic or written request, or in person. No proposal may be withdrawn after the time scheduled for opening of proposals, unless the County has failed to comply with the time limits applicable to award of the Contract.

8. **Disclosure of First Tier Subcontractors.** Bidders must submit a subcontractor disclosure statement where the value, estimated by the contracting Agency exceeds \$100,000. The subcontractor disclosure statement may be submitted in the sealed bid prior to the bid closing OR it may be submitted in a separate sealed envelope marked "**SUBCONTRACTOR DISCLOSURE STATEMENT**" and the name of the project, within two (2) working hours after the bid closing. Bidder must submit a statement on the form provided in these contract documents identifying all first-tier subcontractors that will furnish labor or labor and materials and whose contract value is equal to or greater than:

- 5% of the total project bid, but at least \$15,000, or
- \$350,000 regardless of the percentage of the total project bid.

For each subcontractor listed, include:

- The name, address and telephone number of the subcontractor:
- The category of work that the subcontractor would be performing.

If no subcontracts subject to the above disclosure requirements are anticipated, a bidder is required to indicate “**NONE**” on the accompanying form.

To determine disclosure requirements, it is required that bidders disclose subcontract information for any subcontractor as follows:

- 1) Use the forms bound herewith for the required disclosure.

Notice – Bidder’s Requirements: Bidders are required to disclose information about certain first-tier subcontractors when the contract value estimated by the contracting Agency for a Public Improvement is greater than \$100,000 (see ORS 279C.370). Specifically, when the contract amount of a first-tier subcontractor furnishing labor or labor and materials would be greater than or equal to: (i) 5% of the project bid, but at least \$15,000, or
(ii) \$350,000 regardless of the percentage, the bidder must disclose the following information about that subcontract either in its Bid submission or within two working hours after bid closing:

- (a) The subcontractor’s name, and
- (b) The category of work that the subcontractor would be performing.

- 2) If the bidder will not be using any subcontractors that are subject to the above disclosure requirements, the bidder is required to indicate “**NONE**” on the accompanying form.
- 3) Bidder shall submit the disclosure form required by OAR 137-049-0360 either in its bid submission or separately within two working hours after Bid Closing in the manner specified by the invitation to bid.
- 4) Compliance with the disclosure and submittal requirements of ORS 279C.370 and OAR 137-049-0360 is a matter of Responsiveness. Bids which are submitted by Bid Closing, but for which the disclosure submittal has not been made by the specified deadline, are not responsive and shall not be considered for Contract award.
- 5) County shall obtain, and make available for public inspection, the disclosure forms required by ORS 279C.370 and OAR 137-049-0360. County shall also provide copies of disclosure forms to the Bureau of Labor and Industries as required by ORS 279C.835. County is not required to determine the accuracy or completeness of the information provided on disclosure forms.
- 6) Substitution of affected first-tier subcontractors shall be made only in accordance with ORS 279C.585. County shall accept written submissions filed under the statute as public records. Aside from issues involving inadvertent clerical error under ORS 279.585(5), County does not have a statutory role or duty to review, approve, or resolve disputes

concerning such substitutions. See ORS 279C.590 regarding complaints to the Construction Contractors Board on improper substitution.

THE COUNTY MUST REJECT A BID IF THE BIDDER FAILS TO SUBMIT THE DISCLOSURE FORM WITH THIS INFORMATION BY THE STATED DEADLINE (see OAR 137-049-0360).

9. **Bid Security.** The Bid Bond or Cashier's Check will be for a minimum of ten per cent (10%) of the amount of the bid price. If a bidder bids more than one bid proposal, each proposal must be accompanied by separate bid security. The County reserves the right to retain the bid security of the three (3) lowest bidders until the successful bidder has signed and delivered the contract and furnished one hundred percent (100%) Performance and Payment Bonds.
10. **Conditions of Work.** Each bidder must inform himself of the conditions relating to the execution of the work, and make himself thoroughly familiar with all the Contract documents. Failure to do so will not relieve the successful bidder of his obligations to enter into a Contract and complete the contemplated work in strict accordance with the Contract documents. Each bidder must inform himself on all laws and statutes, both Federal and State, relative to the regular execution of the work, the employment of labor, protection of public health, access to the work and similar requirements.
11. **Award of Contract.** The award of the contract will be made by the County on the basis of the proposal which in its sole and absolute judgment will best serve the interest of the County.

County will issue a notice of intent to award contract. Any bidder may protest the notice of intent to award contract within seven (7) calendar days of the notice of intent to award contract.

The County reserves the right to accept or reject any or all proposals, and to waive any informalities and irregularities in said proposals.

12. **Payment and Retainage.** Payment for work performed will be made by the County as specified in the Special Provisions based upon the contract unit prices on the Bid Schedule.

Upon substantial completion of the contract, Contractor may request a partial release of retainage held by the County. The maximum amount of a request for a partial release retainage shall be the Contract amount less 150 percent of the estimated cost of the Contract yet to be performed through final completion. Upon final completion, Contractor may request release of the remaining retainage. Each request for the release of retainage shall be accompanied by the Consent of the contractor's surety.

13. **Performance Bond and Payment Bond.** The successful bidder shall file with the County, at the time of execution of the contract, a Performance Bond and a Payment Bond each of not less than the contract price on the forms furnished by the County. The Surety Company furnishing the required bonds shall have a sound financial standing and a record of service satisfactory to the County, and shall be authorized to do business in the

State of Oregon. In lieu of a Performance Bond, the contractor may file cash, a Certified or Cashier's Check made payable to Deschutes County, Oregon. This money, check or certificate will be held by the County conditioned on and subject to the same provisions as set forth in the attached Performance Bond. ORS 279C.380 allows no flexibility for a cash deposit in lieu of a Payment Bond.

County may request a copy of Contractor's surety bond(s). Contractor must supply County with copy of surety bond(s) within ten (10) calendar days from the date of the request.

14. **Required Public Works Bond.** Before starting work on this project the Contractor and every subcontractor to which Contractor is a party for the performance of work under this contract must have a public works bond filed with the Construction Contractors Board, 700 Summer St. NE, Suite 300, Salem, Oregon 97309-5052, before starting work on the project, unless exempt under section 2 (7) or (8) of 2005 Oregon Laws Chapter 360 ORS 279C.836(7) or (8). Every subcontract to which Contractor is a party for the performance of work under this contract shall contain a provision requiring the subcontractor to have a public works bond filed with the Construction Contractors Board before starting work on this project, unless exempt under ORS 279C.836 (7) or (8) section 2 (7) or (8) of 2005 Oregon Laws Chapter 360.
15. **Failure to Execute Contract.** Upon failure by the successful bidder to enter into the Contract and furnish the necessary bond within ten (10) calendar days from the date Notice of Award is made, the bid bond accompanying the bid shall be forfeited, the proceeds paid to the County, and the award withdrawn. The award may then be made to the next lowest responsible bidder, or all bids rejected and the work is re-advertised.
16. **Disclaimer of Responsibility.** Neither the County nor the Road Department Director will be responsible for oral interpretations. Should a bidder find discrepancies in, or omissions from the drawings, specifications, or other pre-bid documents, or be in doubt as to their meaning, he shall notify the County at least seven (7) calendar working days prior to the bid opening date. Any and all such interpretations, any supplemental instructions or approval of manufacturer's materials to be substituted will be made only in the form of written addenda to the specifications, which, if issued, will be hand delivered or sent by regular mail, email and fax to all prospective bidders receiving a set of such documents, not later than two (2) calendar days prior to the date fixed for the opening of bids. Failure of any bidder to receive any such addendum or interpretation shall not relieve such bidder from any obligation under his bid as submitted. All addenda so issued are to be covered in the bid for such addenda to become part of the Agreement.
17. **Permits and Licenses.** The successful bidder shall be required to have or obtain, at his expense, any and all permits and licenses required by Deschutes County, any City within the County, and the State of Oregon, pertaining to the service he proposes to furnish. Licensing shall include without limitation registration with Construction Contractors Board and in the case of professional engineers and architects proof of current licensing with the appropriate State licensing board.

18. **Minimum Requirements of Bid.** The following minimum requirements as to the form and manner of submitting bids must be strictly observed; variance from these requirements will result in rejection of the bid as unresponsive.
- a. Each Bid must be submitted on forms furnished by the County, and include a complete set of contract documents.
 - b. Each Bid must be signed by the bidder.
 - c. Bid security, in the required form and amount, must accompany each bid.
 - d. Each blank in the proposal must be filled in unless an alternative is provided. Each separate bid item must be bid on, unless the proposal form clearly indicates otherwise.
 - e. Each Bid must be submitted in a separate sealed envelope, marked to identify without opening, and in the hands of the Road Department Director at the time and place specified for bid opening.
 - f. A proposal containing modifications, deletions, exceptions or reservations which in any way conflict with or purport to alter any substantive provision contained in the bid documents, will not be considered.
 - g. A conditional bid will not be considered.
 - h. Any bid submitted without all of the pages of the bid documents, but with a sufficient number of the pages of the bid documents to allow the evaluation of the bid, shall be deemed to have been submitted with the missing pages for purposes of bid evaluation. The missing pages of the bid documents shall be deemed to be incorporated into bid by reference.
19. **Plans.** Plans are not to be taken or construed as being reproduced at precisely the indicated scale. Where the plans are photographic reductions of the original tracings, the approximate amount of reduction is indicated by a note on the plans.
20. **Specifications.** The specifications are the minimum acceptable specifications for the project for which proposals are sought. Any deviation from the specifications contained herein, shall render the bid non-responsive.
21. **Examination of Site and Conditions.** Bidders are required, prior to submission of bids, to carefully examine the site and the Plans and Specifications of the contemplated work. Errors and omissions in the Plans or Specifications shall be called to the attention of the Road Department Director prior to submission of bid so that addenda may be issued. Failure to do so on the part of the Contractor does not relieve him of responsibility for a correct and completely finished job. Only a written interpretation or correction by addendum shall be binding.

22. **Pre-Bid Inquiries.** Bidders with pre-bid inquiries shall contact Cody Smith, County Engineer, in writing at cody.smith@deschutes.org or 61150 SE 27th Street, Bend, Oregon 97702.
23. **Prequalification of Bidders.** Bidders shall be pre-qualified with the State of Oregon in accordance with ORS 279C.430 and Deschutes County Code 12.52.020. The prequalification class is as shown in the Invitation to Bid. This contract is subject to ORS 279C.800 to 279C.870. The successful bidders and subcontractors providing labor shall maintain a qualified drug-testing program for the duration of the contract. Bidders shall be licensed with the Construction Contractor's Board. Contractors and subcontractors need not be licensed under ORS 468.710.
24. **Contract Award.** Deschutes County reserves the right to postpone award of the contract for fourteen (14) calendar days from the date of the bid opening, or until a final decision is made on a protest, whichever is later.
25. **Bidder Statement.** Submission of a bid for the project shall constitute a statement by the bidder that the provisions of ORS 279C.840 are to be complied with.

BID PROPOSAL FORM

PAVING OF HAMBY RD: US 20 TO BUTLER MARKET RD

BIDDER NAME

CCB#

ADDRESS

CITY

STATE

ZIP CODE

CONTACT NAME

CONTACT PHONE NUMBER

CONTACT EMAIL ADDRESS

The undersigned, hereinafter called the Bidder, declares that the only persons or parties interested in this Proposal are those named herein; that this Proposal is, in all respects, fair and without fraud; and it is made without collusion with any official of Deschutes County, Oregon, hereinafter called County; and that the Proposal is made without any connection or collusion with any person making another proposal on this contract.

The Bidder further declares that Bidder has carefully examined the contract documents; that Bidder is satisfied as to the quantities involved, including materials and equipment, and conditions of work involved; and that this proposal is made according to the provisions and under the terms of the contract documents, which documents are hereby made a part of this Proposal.

The Bidder agrees that all of the applicable provisions of Oregon law relating to public contracts (ORS Chapter 279) are, by this reference, incorporated in and made a part of this Proposal. Bidder hereby states that Bidder will comply with ORS 279C.840.

Bidder declares that (check appropriate box):

Bidder is a resident bidder of the State of Oregon.

Bidder is a nonresident bidder from the State of _____.

Bidder declares that Bidder is not in violation of any tax laws of the State of Oregon and Deschutes County, including but not limited to those programs listed in ORS 305.380(4),

The Bidder further agrees that if this Proposal is accepted, Bidder will, within ten (10) calendar days after notification of acceptance, execute the contract with the County in the form of contract annexed hereto; and will, at the time of execution of the contract, deliver to the County the Performance and Payment Bonds (See Section 13 Information for Bidders) required herein; and will, to the extent of this Proposal, furnish all materials necessary to complete the work in the manner, in the time, and according to the methods as specified in the contract documents and required by the Road Department Director.

Bidder certifies that it has a drug testing program in place for its employees, or warrants that a drug testing program will be in place prior to execution of this contract, that the drug testing program is in writing, that new employees must pass a drug screening, that existing employees may be tested for reasonable cause or when an employee is injured or involved in an accident resulting in property

damage. Bidder agrees that each subcontractor providing labor under this Contract shall maintain a qualifying drug testing program for the duration of the Contract.

The Bidder agrees to commence work upon the issuance of a "Notice to Proceed" by the County and fully complete the project according to the time schedule specially set forth in the contract documents.

Bidder further agrees to pay liquidated damages for failure to complete within the specified time.

It is agreed that if the Bidder is awarded the contract for the work herein proposed and shall fail or refuse to execute the contract and furnish the contract and furnish the specified Performance and Payment Bond within ten (10) calendar days after receipt of notification of acceptance of Bidder's proposal, then, in that event, the bid security deposited herewith according to the conditions of the Invitation to Bid and Information for Bidders shall be retained by the County as liquidated damages; and it is agreed that the said sum is a fair measure of the amount of damage the County will sustain in case the Bidder shall fail or refuse to enter into the contract for the said work and to furnish the Performance and Payment Bonds (See Section 13 Information for Bidders) as specified in the contract documents. Bid security in the form of a certified check shall be subject to the same requirements as a bond.

(IF SOLE PROPRIETOR OR PARTNERSHIP)

IN WITNESS HERETO, the undersigned has set hand this _____ day of _____, 2022.

SIGNATURE OF BIDDER

TITLE

(IF CORPORATION)

IN WITNESS WHEREOF, the undersigned corporation has caused this instrument to be executed and its seal affixed by its duly authorized officers this _____ day of _____, 2022.

NAME OF CORPORATION

By: _____

Title: _____

Attest: _____

(SCHEDULE OF BID ITEMS TO FOLLOW)

ITEM NO.	SPEC SECTION	ITEM	UNIT	QTY	UNIT PRICE	AMOUNT
<u>Part 00200 - Temporary Features and Appurtenances</u>						
001	00210	Mobilization	LS	1	\$ _____	\$ _____
002	00221	Temporary Protection and Direction of Traffic	LS	1	\$ _____	\$ _____
003	00222	Temporary Signs	SQFT	740	\$ _____	\$ _____
004	00222	Portable Changeable Message Signs	EACH	4	\$ _____	\$ _____
005	00223	Flaggers	HOUR	432	\$ _____	\$ _____
006	00223	Pilot Cars	HOUR	144	\$ _____	\$ _____
<u>Part 00400 - Drainage and Sewers</u>						
007	00490	Adjusting Boxes	EACH	9	\$ _____	\$ _____
<u>Part 00600 - Bases</u>						
008	00620	Cold Plane Pavement Removal, 0-2 Inches Deep	SQYD	3190	\$ _____	\$ _____
009	00640	Aggregate Shoulders	TON	2556	\$ _____	\$ _____
<u>Part 00700 - Wearing Surfaces</u>						
010	00744	Level 3, 1/2 inch ACP Mixture	TON	5575	\$ _____	\$ _____
011	00748	13-Inch Asphalt Concrete Pavement Repair	SQYD	44	\$ _____	\$ _____
012	00749	Extra for Asphalt Approaches	EACH	15	\$ _____	\$ _____
<u>Part 00800 - Permanent Traffic Safety and Guidance Devices</u>						
013	00855	Bi-Directional Yellow Type 1AR Markers, Recessed	EACH	278	\$ _____	\$ _____
014	00865	Thermoplastic, Extruded or Sprayed, Surface, Non-Profiled	FOOT	70500	\$ _____	\$ _____
015	00867	Pavement Bar, Type AB	SQFT	456	\$ _____	\$ _____
016	00867	Pavement Legend, Type B-HS: "SCHOOL"	EACH	2	\$ _____	\$ _____
017	00867	Pavement Legend, Type B-HS: "STOP"	EACH	5	\$ _____	\$ _____
018	00867	Pavement Legend, Type B-HS: "STOP AHEAD"	EACH	5	\$ _____	\$ _____

TOTAL BID: _____

FOR DESCHUTES COUNTY USE ONLY	
ADD	% FOR NON-RESIDENT BIDDER _____
TOTAL BID _____	

The Bidder acknowledges receipt of the following Addenda: (insert addenda numbers)

No.____ No.____ No.____ No.____ No.____ No.____ No.____ No.____

FIRST-TIER SUBCONTRACTOR DISCLOSURE FORM

Project Name: PAVING OF HAMBY RD: US 20 TO BUTLER MARKET RD

Bid #: W66116 Bid Closing Date: June 1, 2022 Time: 2:00 P.M.

Name of Bidding Contractor: _____

This form must be submitted at the location specified in the Invitation to Bid on the advertised bid closing date and within two working hours (4:00 p.m.) after the advertised bid closing time.

List below the name of each subcontractor that will be furnishing labor or materials and that is required to be disclosed, the category of work that the subcontractor will be performing and the dollar value of the subcontract. Enter "NONE" if there are no subcontractors that need to be disclosed. (ATTACH ADDITIONAL SHEETS IF NEEDED).

	NAME	DOLLAR VALUE	CATEGORY OF WORK
1)	_____	\$ _____	_____
2)	_____	\$ _____	_____
3)	_____	\$ _____	_____
4)	_____	\$ _____	_____
5)	_____	\$ _____	_____
6)	_____	\$ _____	_____
7)	_____	\$ _____	_____
8)	_____	\$ _____	_____

Failure to submit this form by the disclosure deadline will result in a non-responsive bid. A non-responsive bid will not be considered for award.

Form submitted by

Bidder name: _____

Contact name: _____ Phone number: _____

BID BOND

KNOW ALL MEN BY THESE PRESENTS, That _____

hereinafter called the Principal, and _____

a corporation duly organized under the laws of the State of _____

having its principal place of business at _____

_____, in the State of _____

and authorized to do business in the State of Oregon, as Surety, are held and firmly bound unto the

County of Deschutes, hereinafter called the Obligee, in the penal sum of _____

_____ DOLLARS (\$_____),

for the payment of which, well and truly to be made, we bind ourselves, our heirs, executors, administrators, successors and assigns, jointly and severally, firmly by these presents.

The condition of this Bond is that, whereas, the Principal is submitting a bid proposal for the PAVING OF HAMBY RD: US 20 TO BUTLER MARKET RD project hereby made a part hereof;

NOW THEREFORE, if the said bid proposal submitted by the said principal be accepted, and the contract be awarded to said Principal, and if the said Principal shall execute the proposed contract and shall furnish the Performance and Payment Bond as required by the bidding and contract documents with the time fixed by said documents, then this obligation shall be void, otherwise to remain in full force and effect. Signed and sealed this ____ day of _____, 2022.

SURETY:

CONTRACTOR:

Name

Name

By: _____

By: _____

Title: _____

Title: _____

CONTRACT

FOR

PAVING OF HAMBY RD: US 20 TO BUTLER MARKET RD

THIS CONTRACT is made and entered into this _____ day of _____, 2022, by and between DESCHUTES COUNTY, a political subdivision of the State of Oregon, by and through its Board of County Commissioners, hereinafter called "County", and _____, an Oregon corporation, hereinafter called "Contractor."

WITNESSTH:

THAT the said Contractor, in consideration of the sums to be paid by the County in the manner and at the time herein provided, and in consideration of the other covenants and agreements herein contained, hereby agrees to perform and complete the work herein described and provided for and to furnish all necessary machinery, tools, apparatus, equipment, supplies, materials and labor and do all things in accordance with the applicable Plans, the applicable Standard Specifications, the Special Provisions and other required provisions bound herewith or incorporated therein, and in accordance with such alterations or modifications of the same as may be made by the County, and according to such directions as may from time to time be made or given by the Engineer under the authority and within the meaning and purpose of this Contract. This agreement shall be binding upon the heirs, executors, administrators, successors and assigns of the Contractor.

THAT the applicable Plans, the applicable Standard Specifications, the Special Provisions and other required provisions bound herewith or incorporated therein and the Schedule of Items bound herewith are hereby specifically referred to and by this reference made a part hereof, and shall by such reference have the same force and effect as though all of the same were fully written or inserted herein.

THAT the Contractor shall faithfully complete and perform all of the obligations of this Contract, and in particular, shall promptly, as due, make payment of all just debts, dues, demands and obligations incurred in the performance of said Contract; and shall not permit any lien or claim to be filed or prosecuted against the County, its agents or employees. It is expressly understood that the laws of the State of Oregon and the Ordinances of the County shall govern this Contract in all things.

THAT in consideration of the faithful performance of all of the obligations, general and special, herein set out, and in consideration of the faithful performance of the work as set forth in the Contract Documents in accordance with the directions and to the satisfaction of the Engineer, the County agrees to pay to the said Contractor the amount earned, as determined from the actual quantities of work performed, and taking into consideration any amounts that may be deductible and under the terms of the Contract, and to make such payments in the manner and at the times provided in the applicable provisions.

(SIGNATURE PAGE TO FOLLOW)

IN WITNESS WHEREOF, the parties hereto have subscribed their names and affixed their respective official seals as of the date first above written

CONTRACTOR

**BOARD OF COUNTY COMMISSIONERS
OF DESCHUTES COUNTY, OREGON**

BY: _____

PATTI ADAIR, CHAIR

TITLE: _____

ANTHONY DeBONE, VICE CHAIR

DATE: _____

PHIL CHANG, COMMISSIONER

ATTEST:

RECORDING SECRETARY

APPROVED AS TO CONTENT:

ROAD DEPARTMENT DIRECTOR

APPROVED AS TO FORM:

COUNTY LEGAL COUNSEL

Bond # _____

PERFORMANCE BOND

KNOW ALL MEN BY THESE PRESENTS: that

(Name of Contractor)

(Address of Contractor)

a _____, hereinafter called
(Corporation, Partnership, or Individual)

“Principal”, and _____
(Name of Surety)

hereinafter called “Surety”, are held and firmly bound unto Deschutes County, Oregon

hereinafter called “Owner”, in the penal sum of _____

_____ Dollars, \$(_____) in lawful money of the United States, for the payment of which sum well and truly to be made, we bind ourselves, successors, and assigns, jointly and severally, firmly by these presents.

THE CONDITION OF THIS OBLIGATION is such that whereas, the Principal entered into a certain contract with the OWNER, dated the _____ day of _____, 2022, a copy of which is hereto attached and made a part hereof for the construction of:

PAVING OF HAMBY RD: US 20 TO BUTLER MARKET RD

NOW THEREFORE, if Principal shall well, truly and faithfully perform its duties, all the undertakings, covenants, terms, conditions, and agreements of said contract during the original term thereof, and any extensions thereof which may be granted by Owner, with or without notice to Surety and during the **two year guaranty period**, and if Principal shall satisfy all claims and demands incurred under such contract, and shall fully indemnify and save harmless Owner from all costs and damages which is may suffer by reason of failure to do so, and shall reimburse and repay Owner all outlay and expense which Owner may incur in making good any default, then this obligation shall be void; otherwise to remain in full force and effect.

PROVIDED FURTHER, that Surety, for value received hereby stipulates and agrees that no change, extension of time, alteration or addition to the terms of the contract or to work to be performed thereunder or the specifications accompanying the same shall in any wise affect its obligation on this bond, and it does hereby waive notice of any such change, extension of time, alteration or addition to the terms of the contract or to the work or the specifications.

PROVIDED, FURTHER, that no final settlement between Owner and Principal shall abridge the right of any beneficiary hereunder, whose claim may be unsatisfied.

IN WITNESS WHEREOF, this instrument is executed in two counterparts, each one of which shall be deemed an original, this the _____ day of _____ 2022.

(SEAL)

PRINCIPAL: _____

By _____
Signature

Official Capacity

Attest: _____
Corporation Secretary

(SEAL)

SURETY: _____
[Add signatures for each surety if using multiple bonds]

BY ATTORNEY-IN-FACT:
[Power-of-Attorney must accompany each surety bond]

Name

Signature

Address

City State Zip

Phone Fax

NOTE: Date of bond must not be prior to date of Contract.
If Contractor is Partnership, all partners should execute bond.

Bond # _____

PAYMENT BOND

KNOW ALL MEN BY THESE PRESENTS: that

(Name of Contractor)

(Address of Contractor)

a _____, hereinafter called
(Corporation, Partnership, or Individual)

“Principal”, and _____
(Name of Surety)

hereinafter called “Surety”, are held and firmly bound unto Deschutes County, Oregon

hereinafter called “Owner”, in the penal sum of _____

_____ Dollars, \$(_____) in lawful money of the United States, for the payment of which sum well and truly to be made, we bind ourselves, successors, and assigns, jointly and severally, firmly by these presents.

THE CONDITION OF THIS OBLIGATION is such that whereas, the Principal entered into a certain contract with the OWNER, dated the _____ day of _____, 2022, a copy of which is hereto attached and made a part hereof for the construction of:

PAVING OF HAMBY RD: US 20 TO BUTLER MARKET RD

NOW, THEREFORE, if Principal shall promptly make payment to all persons, firms, subcontractors, and corporations furnishing materials for or performing labor in the prosecution of the work provided for in such contract, and any authorized or modification thereof, including all amounts due for materials, lubricants, oil, gasoline, coal and coke, repairs on machinery, equipment and tools, consumed or used in connection with the construction of such work, and all insurance premiums on said work, and for all labor, performed in such work whether by subcontractor or otherwise, then this obligation shall be void; otherwise to remain in full force and effect.

PROVIDED, FURTHER, that Surety for value received hereby stipulates and agrees that no change, extension of time, alteration or addition to the terms of the contract or to the work to be performed thereunder or the specifications accompanying the same shall in any wise affect its obligation on this bond, and it does hereby waive notice of any such change, extension of time, alteration or addition to the terms of the contract or to the work or to the specifications.

PROVIDED, FURTHER, that no final settlement between Owner and Principal shall abridge the right of any beneficiary hereunder, whose claim may be unsatisfied.

IN WITNESS WHEREOF, this instrument is executed in two counterparts, each one of which shall be deemed an original, this the _____ day of _____, 2022.

(SEAL)

PRINCIPAL: _____

By _____
Signature

Official Capacity

Attest: _____
Corporation Secretary

(SEAL)

SURETY: _____
[Add signatures for each surety if using multiple bonds]

BY ATTORNEY-IN-FACT:
[Power-of-Attorney must accompany each surety bond]

Name

Signature

Address

City State Zip

Phone Fax

NOTE: Date of bond must not be prior to date of Contract.
If Contractor is Partnership, all partners should execute bond.

SPECIAL PROVISIONS

PROJECT: PAVING OF HAMBY RD:
US 20 TO BUTLER MARKET RD

PROJECT #: W66116

CONTRACTING AGENCY:



**ROAD
DEPARTMENT**

**61150 SE 27TH STREET
BEND, OREGON 97702
PHONE: (541) 388-6581
FAX: (541) 388-2719
WEB: www.deschutescounty.gov/road**

PROFESSIONAL OF RECORD CERTIFICATION:

<p>Seal w/signature</p>  <p>REGISTERED PROFESSIONAL ENGINEER 83448PE OREGON NOVEMBER 10, 2009 CODY C. SMITH RENEWS: JUNE 30, 2022</p>	<p>I certify the Special Provision Section(s) listed below are applicable to the design for the subject project. Modified Special Provisions were prepared by me or under my supervision.</p> <p>Sections <u>00210 through 02630</u></p>
<p>Date Signed: <u>5-16-22</u></p>	

SPECIAL PROVISIONS

WORK TO BE DONE

The work to be done under this contract consists of the following on the PAVING OF HAMBY RD: US 20 TO BUTLER MARKET RD project:

1. Install and maintain temporary traffic control.
2. Perform cold plane pavement removal on roadway and approaches, as appropriate.
3. Construct new asphalt concrete pavement.
4. Adjust existing water valve boxes.
5. Place aggregate shoulders, as appropriate.
6. Install recessed pavement markers and permanent pavement markings.
7. Perform additional and incidental work as called for by the specifications and plans.

APPLICABLE SPECIFICATIONS

The Specification that is applicable to the Work on this Project is the 2021 edition of the "Oregon Standard Specifications for Construction."

All number references in these Special Provisions shall be understood to refer to the Sections and subsections of the Standard Specifications and Supplemental Specifications bearing like numbers and to Sections and subsections contained in these Special Provisions in their entirety.

Copies of the Oregon Standard Specifications may be purchased or viewed online at

http://www.oregon.gov/ODOT/Business/Pages/Standard_Specifications.aspx.

APPLICABLE RULES

The rules applicable to this contract are the Attorney General's Model Public Contract Rules, Chapter 137-046 and Chapter 137-049, as presently constituted and Deschutes County Code (DCC) Chapter 2.37. The provisions of DCC Chapter 2.37.150 are incorporated herein by reference. These provisions may be viewed at the following web address:

<https://www.deschutescounty.gov/administration/page/county-code>

CONTRACT TIME

The Contractor shall not begin On-Site Work before June 20, 2022, unless approved by the Engineer. The Contractor shall complete all Work to be done under the Contract not later than September 2, 2022.

CLASS OF WORK

The Class of Work for this Project is Asphalt Concrete Paving and Oiling.

SECTION 00110 - ORGANIZATION, CONVENTIONS, ABBREVIATIONS AND DEFINITIONS

Comply with Section 00110 of the Standard Specifications modified as follows:

00110.20 Definitions - Replace the definitions of the words and phrases list below with the following definitions :

Agency – County of Deschutes

Bid Booklet - The version that can be accessed and printed from the Deschutes County Bids and RFPs website, which contains the information identified in 00120.10.

Engineer - The Road Department Director of Deschutes County acting either directly or through his authorized representatives.

SECTION 00120 - BIDDING REQUIREMENTS AND PROCEDURES

Comply with Section 00120 of the Standard Specifications modified as follows:

00120.00 Prequalification of Bidders – Replace the last paragraph with the following:

Deschutes County Road Department will regularly evaluate the performance of Contractors on its projects for purposes of responding to reference checks, future prequalification and determinations of responsibility.

00120.01 General Bidding Requirements - Replace this subsection with the following:

Bidders shall submit bids by paper.

The standard prequalification forms furnished by the ODOT Procurement Office shall be used by the bidder to file authorized signatures with Deschutes County Road Department. Signatures are of personnel authorized to submit Bids, modify Bids, or withdraw Bids.

00120.05 Request for Solicitation Documents – Replace this subsection with the following:

Bidders shall obtain solicitation documents from the Deschutes County Bids and RFPs website:

<https://www.deschutescounty.gov/rfps>

Each request shall include both the name of the person ordering or obtaining the Solicitation Documents, and the name of the Entity intending to use them. The Agency will add the name of the Entity intending to use the Solicitation Documents to the list of Holders of Bidding Plans. Bidders are cautioned that only Solicitation Documents obtained properly from the Deschutes County website may be used to submit Bids.

Only paper Bids will be accepted.

Copies of the Oregon Standard Specifications may be purchased or viewed online at

http://www.oregon.gov/ODOT/Business/Pages/Standard_Specifications.aspx.

The Plans, which are applicable to the Work to be performed under the Contract, are bound herewithin.

00120.10 Bid Booklet – Replace this subsection with the following:

The Bidding Documents Booklet may include, but is not limited to:

- Cover Page
- Index
- Invitation to Bid
- Information for Bidders
- Bid Proposal Form
- Schedule of Bid Items
- Subcontractor Disclosure Form
- Bid Guaranty Form
- Contract Form (for review only)
- Payment and Performance Bond Forms (for review only)

Depending on the Class of Project, other certificates or statements may be bound within the Bidding Documents Booklet. Plans, specifications, and other documents referred to in the Bidding Documents Booklet will be considered part of the Bid.

00120.30 Changes to Plans, Specifications, or Quantities before Opening of Bids
– Replace the first paragraph with the following:

The Agency reserves the right to issue Addenda making changes or corrections to the Plans, Specifications, or quantities. The Agency will provide Addenda only by publishing them on the Agency's web site at:

<https://www.deschutescounty.gov/rfps>

00120.40(a) (1) Paper Bids – Replace this subsection with the following:

For Bids submitted by paper, Bidders shall not alter, in any manner, the (paper) documents within the Bid Section that are accessed and printed from the Deschutes County Bids and RFPs website. Bidders shall complete the certifications and statements included in the Bid Section of the Bid Booklet according to the instructions. Signature of the Bidder's authorized representative thereon constitutes the Bidder's confirmation of and agreement to all certifications and statements contained in the Bid Booklet. Entries on paper documents in the Bid Section shall be in ink or typed. Signatures and initials shall be in ink.

The Bidder shall properly complete and bind all the paper documents in the Bid Section, as specified in 00120.10, together with all other required documents that are part of the Bid Booklet, between the front and back covers of the Bid Booklet, except that the Bid

Bond is not required if another permissible type of Bid guaranty is provided. (See 00120.40(e).)

00120.40(a) (2) Electronic Bids – Delete this subsection.

00120.40(c) (2) Electronic Bid Schedule Entries – Delete this subsection.

00120.40 (d) Bidder’s Address and Signature Pages – Replace this subsection with the following:

Bidders shall include in the Bid the address to which all communication concerning the Bid and Contract should be sent. The Bid shall be signed by a duly authorized representative of the Bidder.

00120.40(e) (2) Bid Guaranty with Electronic Bids – Delete this subsection.

00120.40(f) Disclosure of First-Tier Subcontractors – Under the paragraph “The Subcontractor Disclosure Form may be submitted for a paper Bid...” replace the second bulleted item with the following:

- By removing it from the paper Bid Booklet, filling it out and submitting it separately to the Deschutes County Public Works Engineering and Construction Division at the address given in the Bid Booklet.

Delete the third bulleted item.

Delete the paragraph which begins with “The Subcontractor Disclosure Form may be submitted for an electronic Bid...” and subsequent bulleted items.

Replace the paragraph that begins “Subcontractor Disclosure forms submitted by...” with the following:

Subcontractor Disclosure Forms submitted by any method will be considered late if not received by the Agency within two working hours of the time designated for receiving Bids.

00120.45 Submittal of Bids – Replace this subsection with the following:

Bids shall be submitted in the manner and prior to the time listed in the Bidding Documents Booklet. Bids may be submitted by mail, parcel delivery service, or hand delivery. Bids submitted after the time set for receiving Bids will not be opened or considered. The Agency assumes no responsibility for the receipt and return of late Bids.

00120.50 Submitting Bids for More than One Contract – Delete this subsection.

00120.60(a) Paper Bids – Replace all references to “ODOT Procurement Office” with “Agency.”

Delete the third bullet point in the first bulleted list.

00120.60(b) Electronic Bids – Delete this subsection.

00120.70 Rejection of Nonresponsive Bids – Add the following bullet to the end of the bullet list:

- The Agency determines that any Pay Item is significantly unbalanced to the potential detriment of the Agency.

Replace the fifth bullet with the following:

- The Bid is submitted on documents not obtained directly from the Deschutes County Bids and RFPs website, or is submitted by a Bidder who is not registered on the Agency's "Holders of Bidding Plans" list, as required by 00120.05.

Delete the bullet point beginning with "An electronic Bid is not received..."

00120.95 Opportunity for Cooperative Arrangement – Delete this subsection.

SECTION 00130 – AWARD AND EXECUTION

Comply with Section 00130 of the Standard Specifications modified as follows:

00130.10 Award of Contract – Replace the paragraph that begins "The Agency will provide Notice of Intent..." with the following:

The Agency will provide Notice of Intent to Award on the Agency's website:

<https://www.deschutescounty.gov/rfps>

Delete the paragraph that begins "The Award will not be final until..." and subsequent bulleted items.

00130.15 Right to Protest Award – Replace this subsection with the following:

Adversely affected or aggrieved Bidders, limited to the three apparent lowest Bidders and any other Bidder directly in line for Contract Award, may submit to the Board of County Commissioners of Deschutes County a written protest of the Agency's intent to Award within five working days following the Bid Opening. The protest shall specify the grounds upon which it is based.

The Agency will not consider late protests.

00130.50 Execution of Contract and Bonds:

(a) By the Bidder – In the sentence that begins "The successful Bidder..." replace "ODOT Procurement Office – Construction" with "Agency" and replace "15 Calendar Days" with "the requested amount of time".

(b) By the Agency – In the sentence that begins "Within 7 Calendar Days..." replace "7" with "21 (twenty-one)".

SECTION 00140 – SCOPE OF WORK

Comply with Section 00140 of the Standard Specifications.

SECTION 00150 - CONTROL OF WORK

Comply with Section 00150 of the Standard Specifications modified as follows:

00150.05 Cooperative Arrangements – Replace this subsection with the following:

Agency is not, by virtue of this Contract, a partner or joint venturer with Contractor in connection with activities carried out under this Contract, and shall have no obligation with respect to Contractor's debts or any other liabilities of each and every nature.

00150.15(b) Agency Responsibilities - Replace this subsection, except for the subsection number and title, with the following:

The Engineer will:

- Provide copies of plans and specifications.
- Evaluate grade for acceptance at each course of material.
- Perform measurements and calculations for pay quantities.
- Perform final "as constructed" measurements.

00150.15(c) Contractor Responsibilities – Replace this subsection, except for the subsection number and title, with the following:

The Contractor shall:

- Layout and set construction stakes and marks to establish the lines, grades, Slopes, Cross Sections and curve super-elevations for Roadwork to construct the Project as shown and specified, by means approved by the Engineer.
- Make calculations, field notes and survey drawings for the layout and control of work as are necessary to construct the Project as specified.
- Provide original or copies of notes, calculations and drawings as requested.
- Preserve survey monuments and control stations as governed by applicable law.
- Establish control stations as necessary to control the Project.
- Replace and augment control stations as necessary to control the Project.
- Remove and dispose of all flagging, lath, stakes and other temporary staking material after the Project is completed.

00150.50(c) Contractor Responsibilities – Replace the bullet that begins "In addition to the notification required in OAR 952-001-0090(5), notify the Engineer..." with the following bullet:

- In addition to the notification required in OAR 952-001-0090(6), notify the Engineer and the Utility as soon as the Contractor discovers any previously unknown Utility conflicts or issues. Contrary to the OAR, stop excavating until directed by the Engineer and allow the Utility a minimum of two weeks to relocate or resolve the previously unknown Utility issues; and

Add the following subsection:

00150.50(f) Utility Information - There are no anticipated conflicts with Utilities. The Contractor shall contact those Utilities having buried facilities and request that they locate and mark them for their protection prior to construction.

SECTION 00160 – SOURCE OF MATERIALS

Comply with Section 00160 of the Standard Specifications modified as follows:

00160.30 Agency-Furnished Materials – Add the following paragraph:

No Agency materials are being offered for use on this project. Contractor shall provide all required materials.

00160.40 Agency-Furnished Sources– Add the following paragraph:

No Agency sources are being offered for use on this project. Contractor shall provide all required materials.

SECTION 00165 - QUALITY OF MATERIALS

Comply with Section 00165 of the Standard Specifications modified as follows:

00165.03 Testing by Agency – Delete this subsection.

00165.04 Costs of Testing – Delete this subsection.

00165.50(b)(1) Specification Materials – Delete the second sentence.

00165.10(a) Field-Tested Materials – Add the following sentence to the end of this subsection:

This is a Type D project.

SECTION 00170 – LEGAL RELATIONS AND RESPONSIBILITIES

Comply with Section 00170 of the Standard Specifications modified as follows:

Add the following subsection:

00170.09 Debt Limitation - This Contract is expressly subject to the debt limitation of Oregon counties set forth in Article XI, Section 10, of the Oregon Constitution, and is contingent upon funds being appropriated therefore. Any provision herein which would conflict with law are deemed inoperative to that extent.

00170.65(b-1) Minimum Wage Rates – Replace the last two paragraphs in this subsection with the following:

The applicable prevailing wage rates for this project are the most recent version published by the Oregon Labor and Industries at the time the Project was initially advertised (Prevailing Wage Rates for Public Works Contracts, January 1, 2022). The wage rates can be found at the following website:

https://www.oregon.gov/boli/WHD/PWR/Pages/pwr_state.aspx

00170.70(a) Insurance Coverages - Add the following to the end of this subsection:

The following insurance coverages and dollar amounts are required pursuant to this subsection:

Insurance Coverages	Combined Single Limit per Occurrence	Annual Aggregate Limit
Commercial General Liability	\$1,000,000	\$2,000,000
Commercial Automobile Liability	\$1,000,000	(aggregate limit not required)

(d) Additional Insured – Replace this subsection except for the subsection number and title with the following:

The liability insurance coverages of 00170.70(a) shall include an Additional Insured Endorsement specifying the “Deschutes County, and its respective officers, agents, employees, and volunteers and the Deschutes County Board of Commissioners” as Additional Insureds, but only with respect to the Contractor's activities to be performed under the Contract. Coverage shall be primary and non-contributory with any other insurance and self-insurance. The liability coverages of 00170.70(a) that are permitted by the Agency to be obtained by an appropriate Subcontractor shall include all of the foregoing as Additional Insureds and shall also include the Contractor and its officers and employees as Additional Insureds.

Additional Insured Endorsements on the Commercial General Liability shall be written on ISO Form CG 20 10 07 04, or equivalent, with respect to liability arising out of ongoing operations and ISO Form CG 20 37 07 04, or equivalent, with respect to

liability arising out of completed operations. Additional Insured Endorsements shall be submitted with the Certificate(s) of Insurance and must be acceptable to the Agency.

Add the following as Additional Insureds under the Contract:

- Deschutes County and its officers, agents, employees, and volunteers
- Deschutes County Board of Commissioners

(g) Certificate(s) of Insurance - Replace this subsection except for the subsection number and title with the following:

As evidence of the insurance coverages required by the Contract, the Contractor shall furnish Certificate(s) of Insurance to the Agency at the time(s) provided in 00130.50(a). As evidence of insurance coverages required by the Contract but permitted by the Agency under 00170.70(a) to be obtained by an appropriate Subcontractor, the Contractor shall furnish Certificate(s) of Insurance to the Agency for such coverages together with the Contractor's request under 00180.21 for approval of the subcontract with that Subcontractor. The Certificate(s) shall:

- List "Deschutes County and its officers, agents, employees, and volunteers and the Deschutes County Board of Commissioners" as a Certificate holder and as an endorsed Additional Insured;
- Include all required endorsements or copies of the applicable policy language effecting coverage required by the Contract;
- Specify that all liability insurance coverages shall be primary and non-contributory with any other insurance and self-insurance, with exception of Workers' Compensation;
- Include a list of all policies that fall under the Excess/Umbrella Insurance if Excess or Umbrella Insurance is used to meet the minimum insurance requirement.

00170.72 Indemnity/Hold Harmless - Add the following paragraph and bullets to the end of this subsection:

Extend indemnity and hold harmless to the Agency and the following:

- Deschutes County and its officers, agents, and employees
- Deschutes County Board of Commissioners

SECTION 00180 – PROSECUTION AND PROGRESS

Comply with Section 00180 of the Standard Specifications modified as follows:

Add the following subsection:

00180.40(c) Specific Limitations - Limitations of operations specified in these Special Provisions include, but are not limited to, the following:

Limitations	Subsection
Cooperation with Utilities	00150.50

On-Site Work	00180.40(b)
Contract Time	00180.50(h)
Right-of-Way and Access Delays	00180.65
Closed Lanes	00220.40(e)(1)
Maintenance Under Traffic	00620.43
Opening Sections to Traffic	00744.51

Be aware of and subject to schedule limitations in the Standard Specifications that are not listed in this subsection.

00180.41 Project Work Schedules - After the paragraph that begins "One of the following Type..." add the following paragraph:

In addition to the "look ahead" Project Work schedule, a Type A schedule as detailed in the Standard Specifications is required on this Contract.

Add the following subsection:

00180.50(h) Contract Time - The Contractor shall complete all Work to be done under the Contract not later than September 2, 2022.

SECTION 00190 – MEASUREMENT OF PAY QUANTITIES

Comply with Section 00190 of the Standard Specifications.

SECTION 00195 - PAYMENT

Comply with Section 00195 of the Standard Specifications modified as follows:

00195.12(d) Steel Materials Pay Item Selection - Add the following to this subsection:

No Pay Items under this Contract qualify for the steel escalation/de-escalation program for this Project.

00195.50(b) Retainage – Replace the first paragraph of this subsection with the following:

The amount to be retained from progress payments will be 5% of the value of Work accomplished, and will be retained in one of the forms specified in Subsection (c) below. No retainage will be withheld from Work performed as Force Account Work, escalation/de-escalation, bonuses, or other items decided by the Agency.

00195.50(c-2) Cash, Alternate B (Retainage Surety Bond) - Delete this subsection.

00195.50(c-3) Bonds and Securities – Delete this subsection.

00195.50(d) Release of Retainage – Replace this subsection with the following:

As the Work progresses, release of the amounts retained under (b) above will only be considered for Pay Items that have been satisfactorily completed. For purposes of this

Subsection, a Pay Item will be considered satisfactorily completed only if all of the Work for the Pay Item is complete and all contractual requirements pertaining to the Pay Item and Work have been satisfied. Work not included in a Pay Item, or which constitutes part of an uncompleted Pay Item, will not be regarded as satisfactorily completed Work for the purposes of this Subsection.

A determination of satisfactory completion of Pay Items or Work or release of retainage shall not be construed as acceptance or approval of the Work and shall not relieve the Contractor of responsibility for defective Materials or workmanship or for latent defects and warranty obligations.

The Contractor shall comply with all applicable legal requirements for withholding and releasing retainage and for prompt payments, including but not limited to those in ORS Chapters 279C and 701, and 49 CFR 26.29.

SECTION 00196 – PAYMENT FOR EXTRA WORK

Comply with Section 00196 of the Standard Specifications.

SECTION 00197 – PAYMENT FOR FORCE ACCOUNT WORK

Comply with Section 00197 of the Standard Specifications.

SECTION 00199 - DISAGREEMENTS, PROTESTS, AND CLAIMS

Comply with Section 00199 of the Standard Specifications modified as follows:

00199.40 Claim Decision; Review; Exhaustion of Administrative Remedies – Replace the second and third paragraphs with the following:

If the Engineer denies the claim for additional compensation or a combination of additional compensation and Contract Time, in full or in part, according to 00199.40(a), the Contractor may request review of the denial. The disputed claim may then be resolved, in full or in part, at any of the three progressive steps of claim review procedure as set forth in (b) through (d) of this Subsection.

If the Engineer has denied a claim, in full or in part, for Contract Time only according to 00180.80, or has denied a claim, in full or in part, for correction of final compensation according to 00195.95, those disputed claims may then be resolved, in full or in part, at any of the three progressive steps of claim review procedure as specified in (b) through (d) of this Subsection.

Delete the fifth paragraph.

00199.40(b-e) - Replace these subsections in their entirety with the following:

00199.40(b) Step 1: Board of Commissioners Review – The Contractor shall request that the Engineer arrange for a hearing during a regularly scheduled Board of

Commissioners Meeting in order to present the denied or partially denied claim for formal review and discussion. The meeting will take place within 21 Calendar Days of the Agency's receipt of the request, or as otherwise agreed by the parties.

If the Board of Commissioners determines that the Contractor must furnish additional information or documentation to allow proper analysis of the claim, the Engineer will prepare a Board meeting agenda item for a second hearing within 14 Calendar Days, or as otherwise agreed by the parties, at which the Contractor shall present the requested information or documentation.

If the Contractor does not accept the Step 1 decision, the Contractor may, within 10 Calendar Days of receipt of the written decision, request in writing through the Engineer that the claim be advanced to Step 3 or 4 (see (c) and (d) below).

00199(c) Step 2: Arbitration - At this step, the claim will be resolved by binding arbitration before a single arbitrator according to the Construction Industry Arbitration Rules of the American Arbitration Association or such other arbitration service and rules as agreed by the parties.

Arbitration filing costs and any arbitrator's fees will be divided equally between the Agency and the Contractor.

00199(d) Step 3: Litigation – This step applies to appeals of arbitration awards issued in Step 2 at 00199.40(c) above, according to ORS 36.600 through ORS 36.740.

The Contractor must follow each step in order, and exhaust all available administrative remedies before resorting to litigation. Lawsuits must be properly filed in a court of competent jurisdiction within 6 months from the date of the final decision that exhausted the Contractor's available administrative remedies under this Section 00199.

The Contractor shall comply with 00170.00.

SECTION 00210 - MOBILIZATION

Comply with Section 00210 of the Standard Specifications.

SECTION 00220 - ACCOMMODATIONS FOR PUBLIC TRAFFIC

Comply with Section 00220 of the Standard Specifications modified as follows:

00220.02(a) General Requirements - Add the following bullet to the end of the bullet list:

- When an abrupt edge is created by excavation, protect traffic according to the "Excavation Abrupt Edge" and the "Typical Abrupt Edge Delineation" configurations shown on the Standard Drawings.

00220.02(b) Temporary Pedestrian Accessible Route Plan - Add the following bullet to the end of the bullet list:

- For an active Work Area controlled at each end by flaggers and pilot car, provide transportation for pedestrians and bicyclists through the active Work Area according to Section 00223 and Section 00228.

00220.40(e-1) Closed Lanes - Replace this subsection, except for the subsection number and title, with the following:

One Traffic Lane may be closed when allowed, shown, or directed during the following periods of time except as indicated in 00220.40(e)(2):

- Daily, Monday through Friday between 7:00 a.m. and 6:00 p.m.

00220.40(e)(2)(b) Special Events - Add the following to the end of this subsection:

The following special events will occur during this Project:

- Oregon High Desert Classic
 - July 20 through July 24, 2022
 - July 27 through July 31, 2022

SECTION 00221 - COMMON PROVISIONS FOR WORK ZONE TRAFFIC CONTROL

Comply with Section 00221 of the Standard Specifications modified as follows:

00221.03 Traffic Safety and Operations - Replace the bullet that begins “When paving operations create...” with the following bullet:

- When paving operations create an abrupt or sloped edge drop off greater than 1 inch, protect traffic by installing signing according to the "2 Lane, 2 Way Roadway Overlay Area" detail shown on the Standard Drawings. Protect longitudinal and transverse Pavement joints by placing and maintaining an asphalt concrete wedge according to 00221.07(c)(1).

00221.07(c)(1) Paving - Replace this subsection, except subsection number and title, with the following:

When the longitudinal joint is greater than 1 inch in height, install additional TCD according to 00221.03. Complete the placing of ACP and construction of paving joints according to 00735.48, 00735.49, 00743.45, 00744.44, 00744.45, 00745.47, and 00745.48, as applicable.

00221.90(b) Temporary Protection and Direction of Traffic - Delete the bullet that begins “Moving temporary barrier to and from Contractor’s stockpile areas”.

Replace the bullet that begins "When the Schedule of Items does not include ..." with the following bullet:

- Preparing and signing the daily “Traffic Control Inspection Report”, when a TCS is not included in the Schedule of Items or when a TCS is not onsite for a work shift.

SECTION 00222 – TEMPORARY TRAFFIC CONTROL SIGNS

Comply with Section 00222 of the Standard Specifications modified as follows:

00222.40(e) Temporary Sign Placement - Add the following to the end of the bullet list:

- Install beyond each end of the Project, facing outgoing traffic, an "END ROAD WORK" (CG20-2A-24) sign a distance of $(A \div 2)$ according to the "TCD Spacing Table" shown on the Standard Drawings.
- For paving operations on non-freeways, place "ABRUPT EDGE" (CW21-9) and "ROAD WORK XX MPH" (CW20-1a) signs as shown. Use an "XX" value equal to 10 mph below the current posted regulatory speed. If a speed is posted for a temporary regulatory speed reduction, that speed is the current posted regulatory speed.
- For all other moving operations that do not create an abrupt edge adjacent to traffic, omit the "ABRUPT EDGE" signs.
- During pilot car operations, install a 15 by 24-inch "WAIT FOR PILOT CAR" (CR4-20) sign at stop-controlled side roads and accesses intersecting the Highway within the limits of the pilot car operation.
- During pilot car operations, install a 12 by 12-inch "WAIT FOR PILOT CAR" (CR4-20a) sign in private residential driveways accessing the Highway within the limits of the pilot car operation. Place the sign in the driveway facing the private residence and so the sign face is not visible to Public Traffic on the Highway. Do not use the sign for apartments, condominiums or business accesses.
- At accesses, side roads, or residential driveways where "WAIT FOR PILOT CAR" (CR4-20) signs are installed, do not allow traffic to be stopped or held for longer than 20 minutes.
- In addition to the signs, public notification (e.g. flyers, door hangers) may be used to inform the residents that may be affected by the pilot car operations and the "WAIT FOR PILOT CAR" signs.
- For each location of the "WAIT FOR PILOT CAR" sign, closely monitor for traffic compliance, operation, and safety at least once per hour during pilot car operations. If operational issues are observed, or if notified of operational issues, at stop-controlled accesses or side roads utilizing the "WAIT FOR PILOT CAR" (CR4-20) sign, remove the sign and replace it with a flagger.

00222.80(a) Area Basis - Add the following to the end of the paragraph that begins "Temporary signs will...":

No measurement of quantities will be made for "CONSTRUCTION VEHICLE DO NOT FOLLOW" (CW23-14) signs.

No measurement of quantities will be made for "WAIT FOR PILOT CAR" (CR4-20) or (CR4-20a) signs.

00222.90 Payment - Add the following to the end of the paragraph that begins "No separate or...":

No separate or additional payment will be made for furnishing, installing, and maintaining 72 by 24-inch "CONSTRUCTION VEHICLE DO NOT FOLLOW" (CW23-14) signs. Payment will be included in 00221.90(b).

No separate or additional payment will be made for furnishing, installing, and maintaining "WAIT FOR PILOT CAR" (CR4-20) or (CR4-20a) signs. Payment will be included in 00221.90(b).

SECTION 00223 - WORK ZONE TRAFFIC CONTROL LABOR AND VEHICLES

Comply with Section 00223 of the Standard Specifications.

SECTION 00224 - TEMPORARY TRAFFIC CHANNELIZING DEVICES

Comply with Section 00224 of the Standard Specifications modified as follows:

00224.80 Measurement – Replace this section, except for the subsection number and title, with the following:

No measurement will be made for work performed under this section.

00224.90 Payment – Replace this subsection, except for the subsection number and title, with the following:

Work performed under this section will be paid for according to 00221.90(b).

SECTION 00225 - TEMPORARY PAVEMENT MARKINGS

Comply with Section 00225 of the Standard Specifications modified as follows:

00225.80 Measurement – Replace this section, except for the subsection number and title, with the following:

No measurement will be made for work performed under this section.

00225.90 Payment – Replace this subsection, except for the subsection number and title, with the following:

Work performed under this section will be paid for according to 00221.90(b).

SECTION 00228 – TEMPORARY PEDESTRIAN AND BICYCLIST ROUTING

Comply with Section 00228 of the Standard Specifications modified as follows:

00228.80 Measurement – Replace this section, except for the subsection number and title, with the following:

No measurement will be made for work performed under this section.

00228.90 Payment – Replace this subsection, except for the subsection number and title, with the following:

Work performed under this section will be paid for according to 00221.90(b).

SECTION 00290 - ENVIRONMENTAL PROTECTION

Comply with Section 00290 of the Standard Specifications modified as follows:

00290.32 Noise Control – Add the following bullet:

- All construction operations shall be performed between the hours of 7:00 a.m. and 6:00 p.m. on Monday through Friday unless otherwise approved by the Engineer.

SECTION 00490 – WORK ON EXISTING SEWERS AND STRUCTURES

Comply with Section 00490 of the Standard Specifications.

SECTION 00620 - COLD PLANE PAVEMENT REMOVAL

Comply with Section 00620 of the Standard Specifications modified as follows:

00620.43 Maintenance Under Traffic - Replace this subsection, except for the subsection number and title, with the following:

Traffic is not allowed on the cold planed surface. Before opening the area to traffic, pave the surface according to 00744.51.

SECTION 00640 - AGGREGATE BASE AND SHOULDERS

Comply with Section 00640 of the Standard Specifications modified as follows:

00640.10 Materials – Add the following to the end of this subsection:

Aggregate Base and Shoulder Aggregate shall conform to the requirements of Section 02630.

00640.90 Payment – Add the following to the end of this subsection:

Item (b) will include aggregates required for asphalt approaches.

SECTION 00730 - EMULSIFIED ASPHALT TACK COAT

Comply with Section 00730 of the Standard Specifications modified as follows:

00730.11 Emulsified Asphalt - In the paragraph that begins "Obtain samples according to AASHTO T 40..." replace the words "AASHTO T 40" with the words "AASHTO R 66".

00730.42 Preparation of Underlying Surfaces – Add the following to the end of this subsection:

Immediately before applying the tack coat, the surface to be tacked shall be clean and dry. Clean all loose material by brooming, flushing with water or other approved methods. Pavement surface shall be cleaned to the apparent existing edge of pavement. Application of tack coat shall not commence until surface cleanliness has been verified and approved by the Engineer.

00730.44 Applying Tack Coat - Apply the Emulsified Asphalt with a pressure distributor conforming to 00730.22, unless otherwise allowed. Apply the Emulsified Asphalt to the prepared surface at a rate between 0.05 and 0.20 gallons per square yard as directed and with the Emulsified Asphalt temperature between 140 °F and 185 °F as recommended by the manufacturer. Refer to the manufacturer's recommendations for tack coat application rates for the underlying surface type and type of emulsion used. Application rates for tack coat diluted according to 00730.11 will be increased as necessary to provide the same amount of residual asphalt as the application rates specified above.

Do not place hot mixed asphalt concrete Pavement or Emulsified Asphalt Concrete Pavement on the tack coat until the Emulsified Asphalt separates from the water (breaks), but before it loses its tackiness. Refer to manufacturer recommendations regarding break/set time.

00730.90 Payment - Replace this subsection, except for the subsection number and title, with the following:

No separate or additional payment will be made for Emulsified Asphalt tack coat. Approximately 4 tons of Emulsified Asphalt in tack coat will be required on this Project.

SECTION 00744 - ASPHALT CONCRETE PAVEMENT

Comply with Section 00744 of the Standard Specifications modified as follows:

00744.10(a) New Coarse and Fine Aggregates – Replace the last paragraph in this subsection with the following:

Test Aggregates for soundness, durability, and harmful substances at no additional cost to the Agency.

00744.11(a) Asphalt Cement - Add the following to the end of this subsection:

Provide PG 58-34 grade asphalt cement for this Project.

00744.16 Sampling and Testing - Replace this subsection, except for the subsection number and title, with the following:

For each 1,000 Tons of placement, have a CAT I perform a minimum of one of each of the following test methods as modified in the MFTP:

- Asphalt Content - AASHTO T 308 with ODOT TM 323 determined Calibration Factor
- Gradation - AASHTO T 30
- Mix Moisture - AASHTO T 329
- Maximum Specific Gravity - AASHTO T 209
- Field Compacted Gyratory Specimens - ODOT TM 326

When less than 1,000 Tons of mix is placed in a Day, perform a minimum of one series of tests per Day. Provide test results to the Engineer by the middle of the following work shift.

If less than three samples are obtained on a Project, the Contractor may supplement test results with the Engineer's approval by:

- Accelerating testing.
- Providing test results from other projects with the same JMF within the past 120 days of first date of JMF production.
- Testing back up samples.
- Provide a minimum of three test results.

The Engineer may waive the requirement for any of AASHTO T 308, AASHTO T 30, AASHTO T 329, and ODOT TM 326 on a daily basis. The Engineer may waive the requirement for AASHTO T 209 when less than 500 Tons of ACP is placed in a single work shift.

Provide samples or split samples to the Engineer when requested.

00744.23 Pavers – Replace the bullet that begins with “Provides the specified...” with the following:

- Provides the specified results through mechanical sensors and sensor-directed devices actuated from independent line and grade control references over an array with a minimum length of 35 feet.

00744.43(b) Depositing – Add the following to this subsection:

ACP shall be windrowed. Pick-up equipment shall be used that is:

- Capable of picking up substantially all of the ACP deposited on the roadway.
- Self-supporting, not exerting any vertical load on the paving machine, or causing vibrations or other motions which could have a harmful effect on the riding quality of the completed pavement.

00744.44(a)(2) Wearing Course – Add the following paragraph to the end of this subsection:

Construct the longitudinal joint between wearing course panels 12 inches from the roadway centerline.

SECTION 00748 - ASPHALT CONCRETE PAVEMENT REPAIR

Comply with Section 00748 of the Standard Specifications modified as follows:

00748.40 Excavation – Replace this subsection, except for the subsection number and title, with the following:

Excavate and remove material to the lines and grades shown or directed. Where abutting surfaces are to be left in place, make clean, vertical cuts with a saw, cutting drum of a pavement planning machine or other approved method.

The Contractor may utilize excavated materials to uniformly widen embankments or to flatten slopes in a manner satisfactory to the Engineer.

After excavating to the lines and grades shown or directed, compact the subgrade materials using a vibratory plate compactor until no reaction, yielding or pumping is observed, or as directed by the Engineer.

Add the following subsection:

00748.46 Timing and Coordination of Work – Asphalt Concrete Pavement Repair shall be performed prior to cold plane pavement removal and mainline paving.

00748.90 Payment - Replace the last paragraph with the following:

No separate or additional payment will be made for excavation, cold plane Pavement removal, asphalt pavement sawcutting, geosynthetics, stone embankment, Aggregate, or water.

SECTION 00749 - MISCELLANEOUS ASPHALT CONCRETE STRUCTURES

Comply with Section 00749 of the Standard Specifications modified as follows:

00749.90 Payment – Replace the paragraph that begins with “Item (a) includes...” with the following:

Item (a) includes road approaches, street connections, alley approaches, driveways, guardrail flares, non-flared guardrail terminals, and mailbox turnouts. No additional payment will be made for minor driveway approaches that are not depicted on the Project Plans.

SECTION 00850 - COMMON PROVISIONS FOR PAVEMENT MARKINGS

Comply with Section 00850 of the Standard Specifications modified as follows:

00850.40(c) Projects Without Striping Plans – Replace the first paragraph of this subsection with the following:

Install striping to match the original striping configuration with the appropriate striping items listed in the Contract Schedule of Items, except in areas with existing narrow double no-pass centerline striping install double no-pass centerline striping. Make additional changes to the centerline striping as directed by the Engineer.

00850.45 Installation - Replace the bullet that begins “Place material according to...” with the following bullet:

- Place material according to the manufacturer’s installation instructions.

SECTION 00855 - PAVEMENT MARKERS

Comply with Section 00855 of the Standard Specifications.

SECTION 00865 - LONGITUDINAL PAVEMENT MARKINGS - DURABLE

Comply with Section 00865 of the Standard Specifications.

SECTION 00867 - TRANSVERSE PAVEMENT MARKINGS - LEGENDS AND BARS

Comply with Section 00867 of the Standard Specifications.

SECTION 02630 – BASE AGGREGATE

Comply with Section 02630 of the Standard Specifications.

##

DESCHUTES COUNTY ROAD DEPARTMENT

PLANS FOR PAVING OF HAMBY RD: US 20 TO BUTLER MARKET RD

May 2022

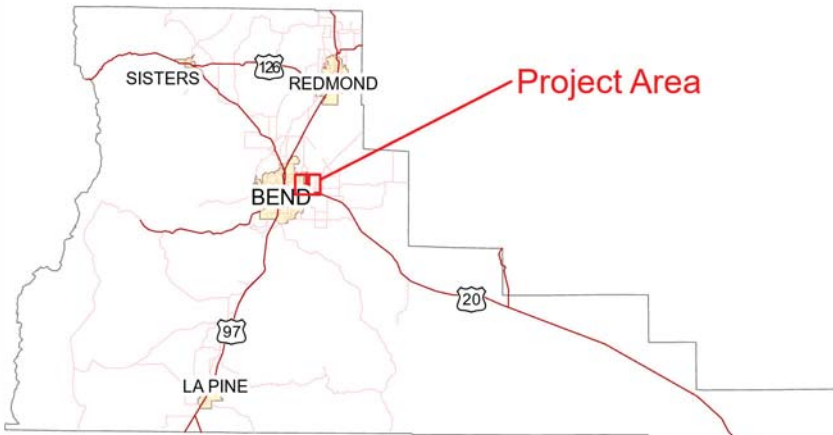

INDEX OF SHEETS

1 COVER SHEET	18 PLAN---QUAIL RIDGE RD Sta 0+12 To 5+00
2 TYPICAL SECTION	19 PLAN---Sta 5+00 To 15+ 00
3 DETAILS	20 PLAN---Sta 15+00 To 20+00
4 REPAIR DETAIL	21 PLAN---Sta 20+00 To END
5 STRIPING DETAILS	22 PLAN---POWDERHORN DR Sta 0+00 To END
6 PLAN---HAMBY RD Sta 6+86 To 15+00	23 PLAN---STONY RIDGE RD Sta 0+00 To END
7 PLAN---Sta 15+00 To 25+00	
8 PLAN---Sta 25+00 To 35+00	
9 PLAN---Sta 35+00 To 40+00	
10 PLAN---Sta 40+00 To 50+00	
11 PLAN---Sta 50+00 To 60+00	
12 PLAN---Sta 60+00 To 70+00	
13 PLAN---Sta 70+00 To 80+00	
14 PLAN---Sta 80+00 To 90+00	
15 PLAN---Sta 90+00 To 100+00	
16 PLAN---Sta 100+00 To 110+ 00	
17 PLAN---Sta 110+00 To END	

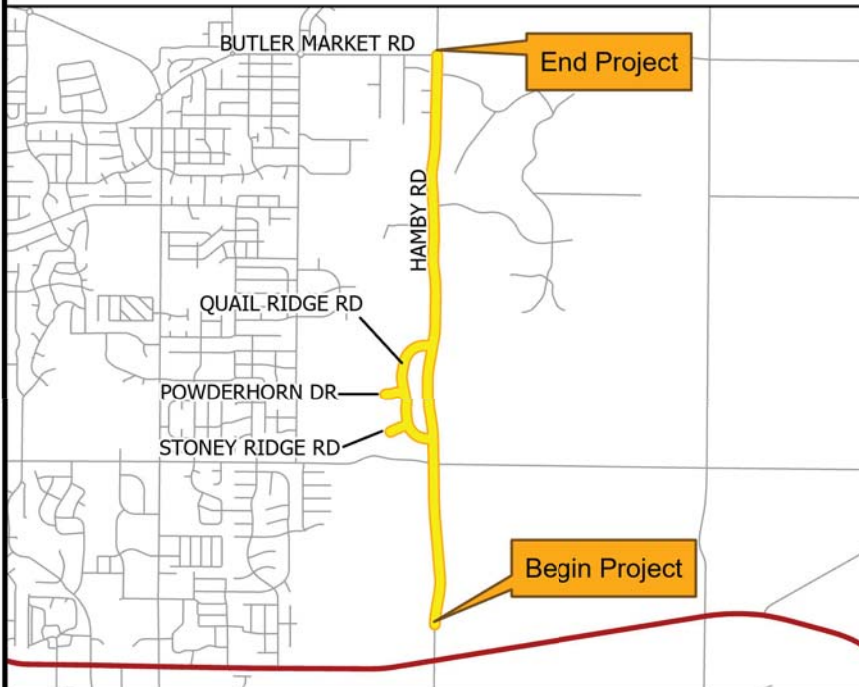

OREGON STANDARD DRAWING NO.

RD610	ASPHALT CONCRETE PAVEMENT (ACP) DETAILS
TM500	PAVEMENT MARKING STANDARD DETAIL BLOCKS
TM502	PAVEMENT MARKING STANDARD DETAIL BLOCKS
TM503	PAVEMENT MARKING STANDARD DETAIL BLOCKS
TM515	PAVEMENT MARKERS
TM517	RECESSED PAVEMENT MARKERS
TM521	DURABLE & HIGH PERFORMANCE PAVEMENT MARKINGS – SURFACE & GROOVE INSTALLED NON-PROFILED
TM530	INTERSECTION PAVEMENT MARKINGS (CROSSWALK, STOP BAR & BIKE LANE STENCIL)
TM560	ALIGNMENT LAYOUT: GENERAL
TM670	WOOD POST SIGN SUPPORTS
TM671	3 SECOND GUST WIND SPEED MAP
TM800	TABLES, ABRUPT EDGE AND PCMS DETAILS
TM821	TEMPORARY SIGN SUPPORTS
TM822	TEMPORARY SIGN SUPPORTS
TM841	INTERSECTION WORK ZONE DETAILS
TM850	2-LANE, 2-WAY ROADWAYS

LOCATION MAP

NOT TO SCALE



LEGEND

- Project Centerline
- State Highway
- Road Centerlines



DESCHUTES COUNTY ROAD DEPARTMENT
61150 S.E. 27TH STREET
BEND, OR, 97702

PHONE: 541-388-6581 FAX: 541-388-2719

PAVING OF HAMBY RD: US 20 to BUTLER MARKET RD

	Date: 2022.05.16 16:02:10 -07'00"
COUNTY ENGINEER	DATE
	Date: 2022.05.16 16:02:37 -07'00"
ROAD DEPT DIRECTOR	DATE
COVER SHEET	SHEET NO. 1 of 23

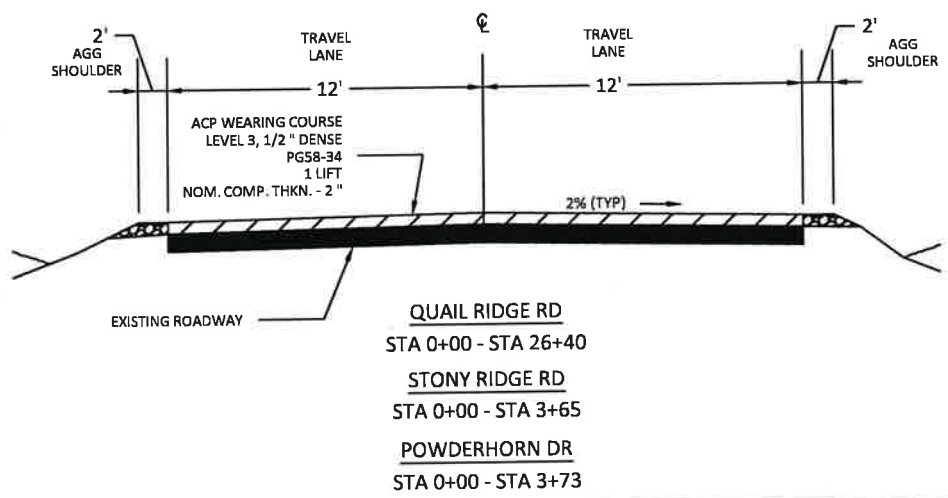
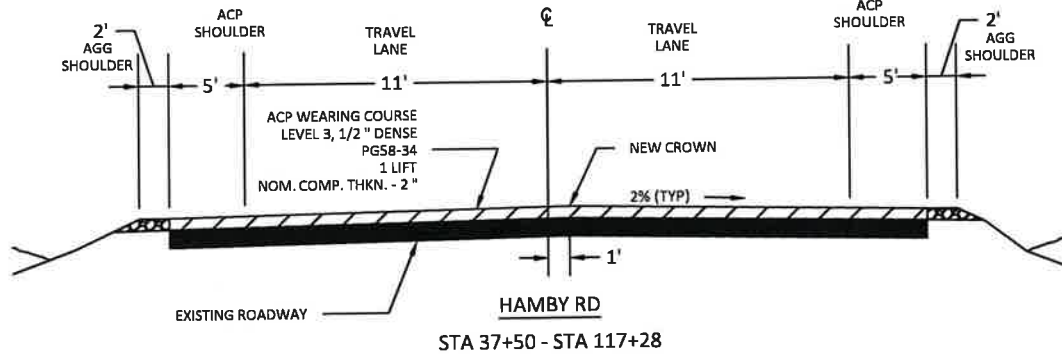
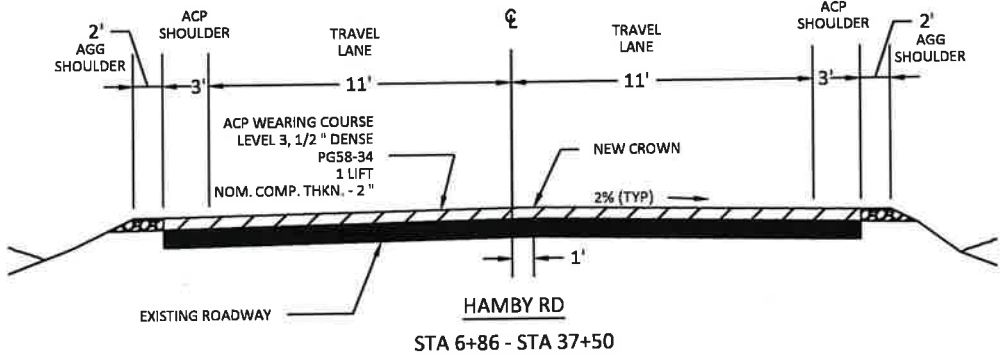

RENEWS: JUNE 30, 2022



DESCHUTES COUNTY ROAD DEPARTMENT
61150 S.E. 27TH STREET
BEND, OR. 97702
PHONE: 541-388-6581 FAX: 541-388-2719

**PAVING OF HAMBY RD:
US 20 TO BUTLER MKT RD**

DRAFTER: T. WILSON DATE: 2/9/22
REVIEWED BY: C. SMITH DATE: 2/9/22

TYPICAL SECTIONS

SHEET NO.
2 OF 23

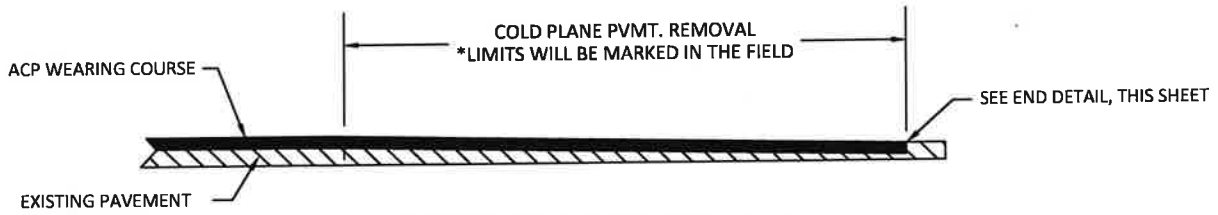

0"-2" COLD PLANE REMOVAL DETAIL
PROFILE VIEW

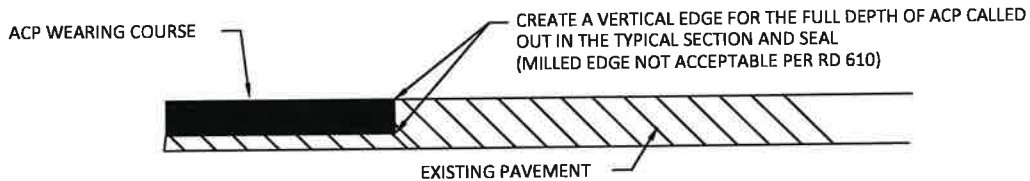

COLD PLANE REMOVAL END DETAIL
PROFILE VIEW

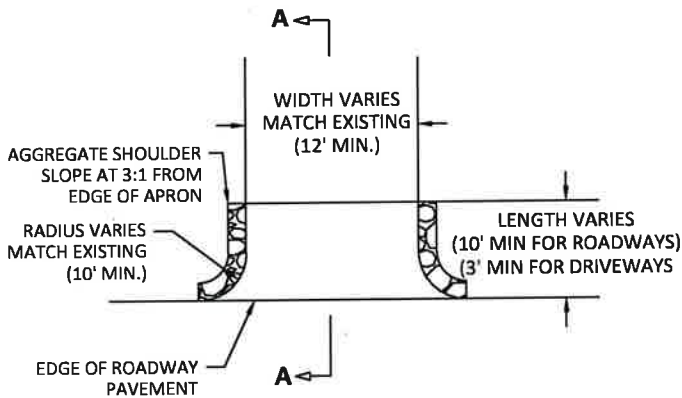

INTERSECTION APPROACH AND DRIVEWAY APRON DETAIL

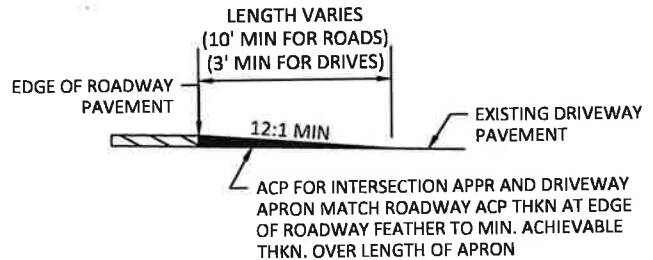

SECTION A-A (EXISTING PAVED APPROACH)

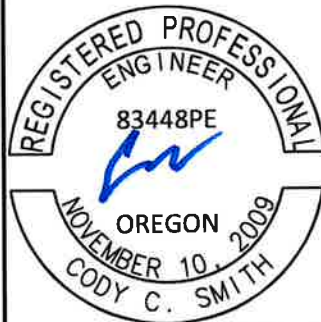

RENEWS: JUNE 30, 2022



DESCHUTES COUNTY ROAD DEPARTMENT

61150 S.E. 27TH STREET
BEND, OR. 97702

PHONE: 541-388-6581

FAX: 541-388-2719

**PAVING OF HAMBY RD:
US 20 TO BUTLER MKT RD**

DRAFTER: T. WILSON

DATE: 2/9/22

REVIEWED BY: C. SMITH

DATE: 2/9/22

DETAILS

SHEET NO.

3 OF 23

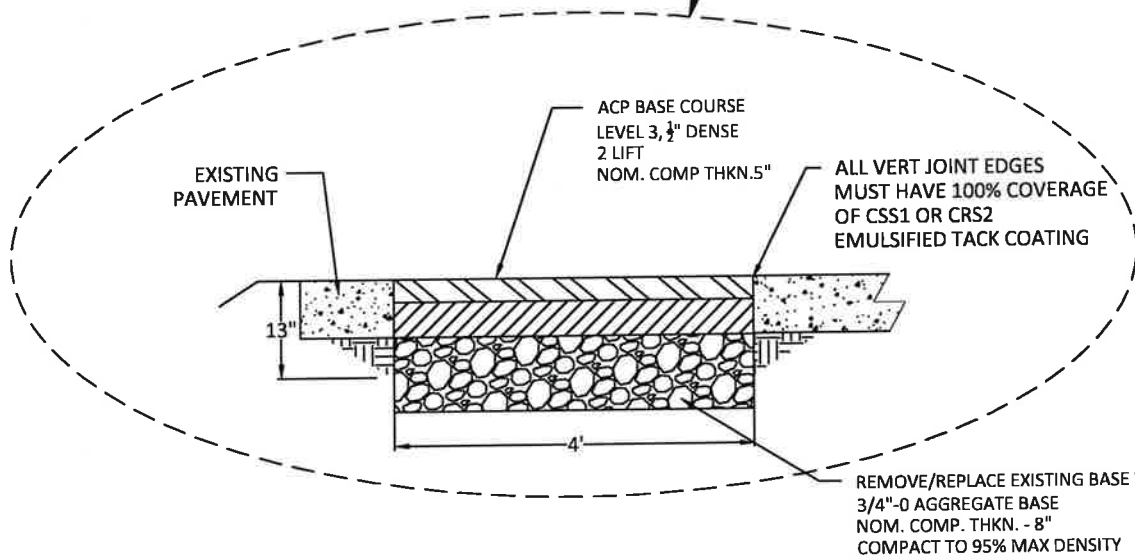
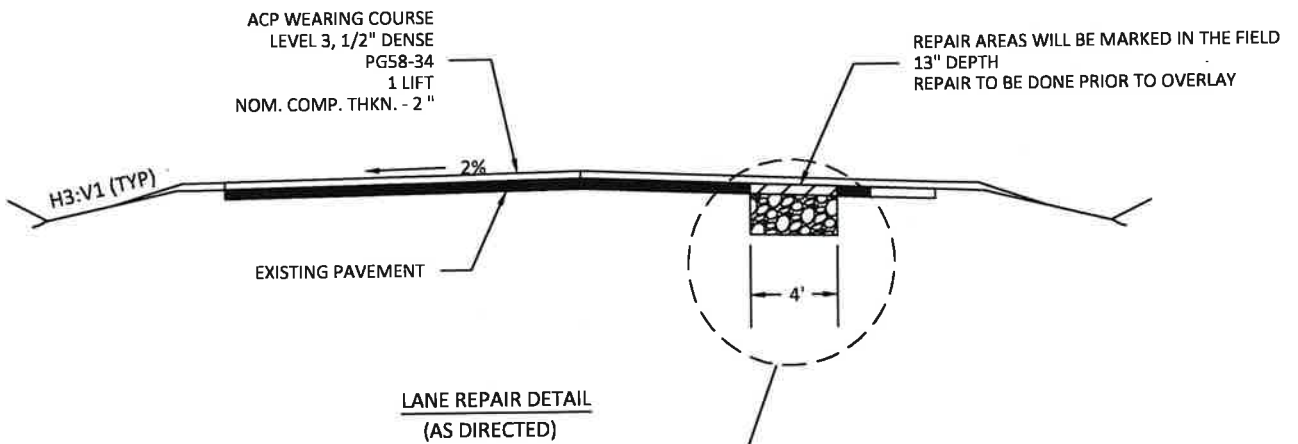

RENEWS: JUNE 30, 2022



DESCHUTES COUNTY ROAD DEPARTMENT

61150 S.E. 27TH STREET
BEND, OR. 97702

PHONE: 541-388-6581

FAX: 541-388-2719

**PAVING OF HAMBY RD:
US 20 TO BUTLER MKT RD**

DRAFTER: T. WILSON

DATE: 2/9/22

REVIEWED BY: C. SMITH

DATE: 2/9/22

REPAIR DETAIL

SHEET NO.

4 OF 23

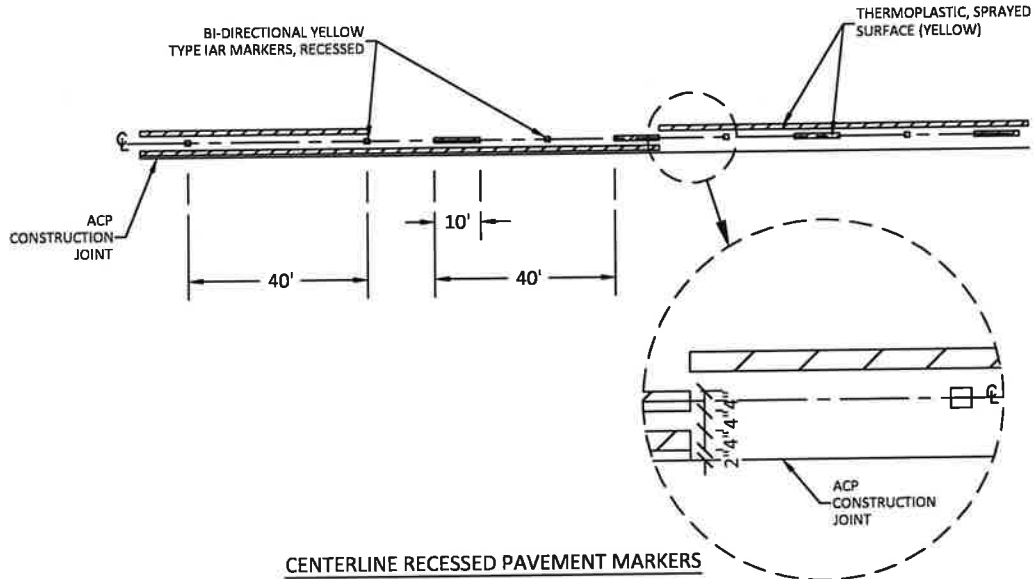

CENTERLINE RECESSED PAVEMENT MARKERS

STA. 6+86 - STA. 117+28

NOTE:

REPLACE EXISTING STRIPING WITH D/R-40, NPL/R-40 AND NPR/R-40 ACCORDING TO EXISTING STRIPING LAYOUT

FOR DETAILS SEE ODOT DWG. TM502, TM 515, TM517, TM521, AND TM561



RENEWS: JUNE 30, 2022



DESCHUTES COUNTY ROAD DEPARTMENT

61150 S.E. 27TH STREET
BEND, OR. 97702

PHONE: 541-388-6581

FAX: 541-388-2719

**PAVING OF HAMBY RD:
US 20 TO BUTLER MKT RD**

DRAFTER: T.WILSON

DATE: 03/14/22

REVIEWED BY: C.SMITH

DATE: 03/14/22

STRIPING DETAILS

SHEET NO.

5 OF 23

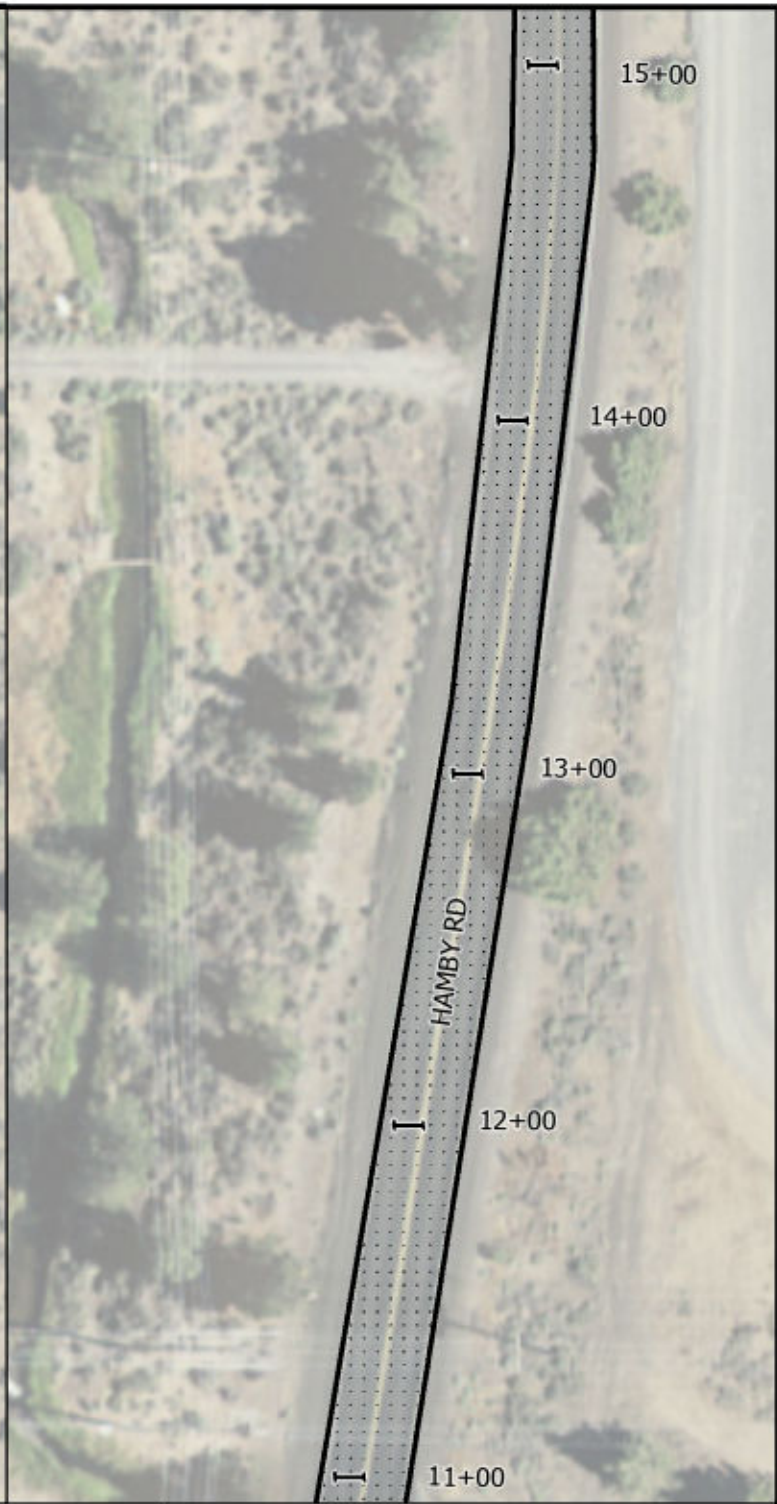
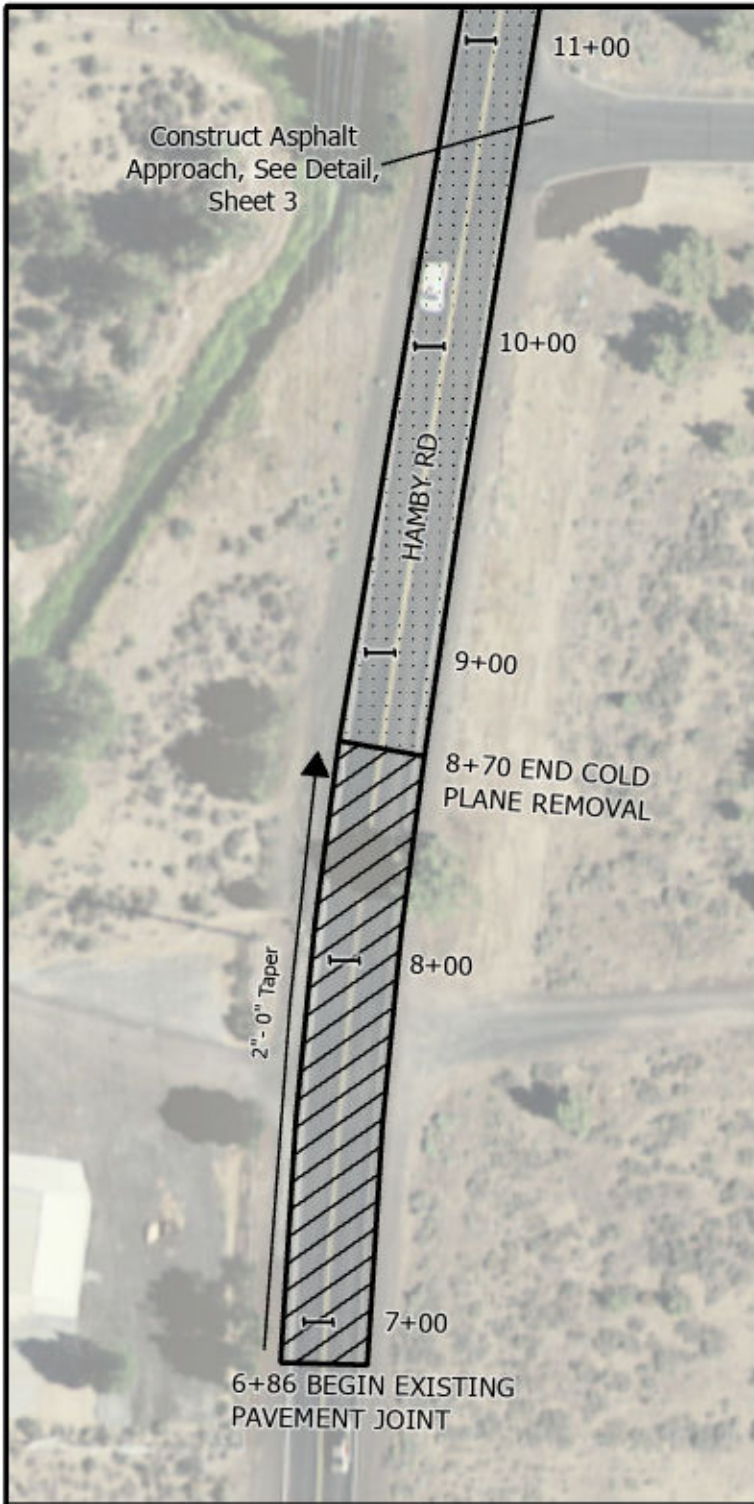

Construct Asphalt Approach, See Detail, Sheet 3

6+86 BEGIN EXISTING PAVEMENT JOINT

2" - 0" Taper

8+70 END COLD PLANE REMOVAL

PLAN
NOT TO SCALE



LEGEND

-  2" - 0" COLD PLANE PAVEMENT REMOVAL
-  2" OVERLAY, FULL-WIDTH (SEE TYPICAL SECTION, SHEET 2)

- NOTES:**
1. INSTALL THERMOPLASTIC CENTERLINE STRIPING AND RECESSED PAVEMENT MARKERS, TYPE D R-40
 2. INSTALL THERMOPLASTIC FOG LINE, TYPE W-2



DESCHUTES COUNTY ROAD DEPARTMENT
61150 S.E. 27TH STREET
BEND, OR, 97702

PHONE: 541-388-6581 FAX: 541-388-2719

**PAVING OF HAMBY RD:
US 20 to BUTLER MARKET RD**

DRAFTER: R. PINKSTON DATE: 5/6/2022
REVIEWED BY: C. SMITH DATE: 5/6/2022

PLAN
BEGIN HAMBY RD
STA 6+86 TO 15+00

SHEET NO.
6 of 23

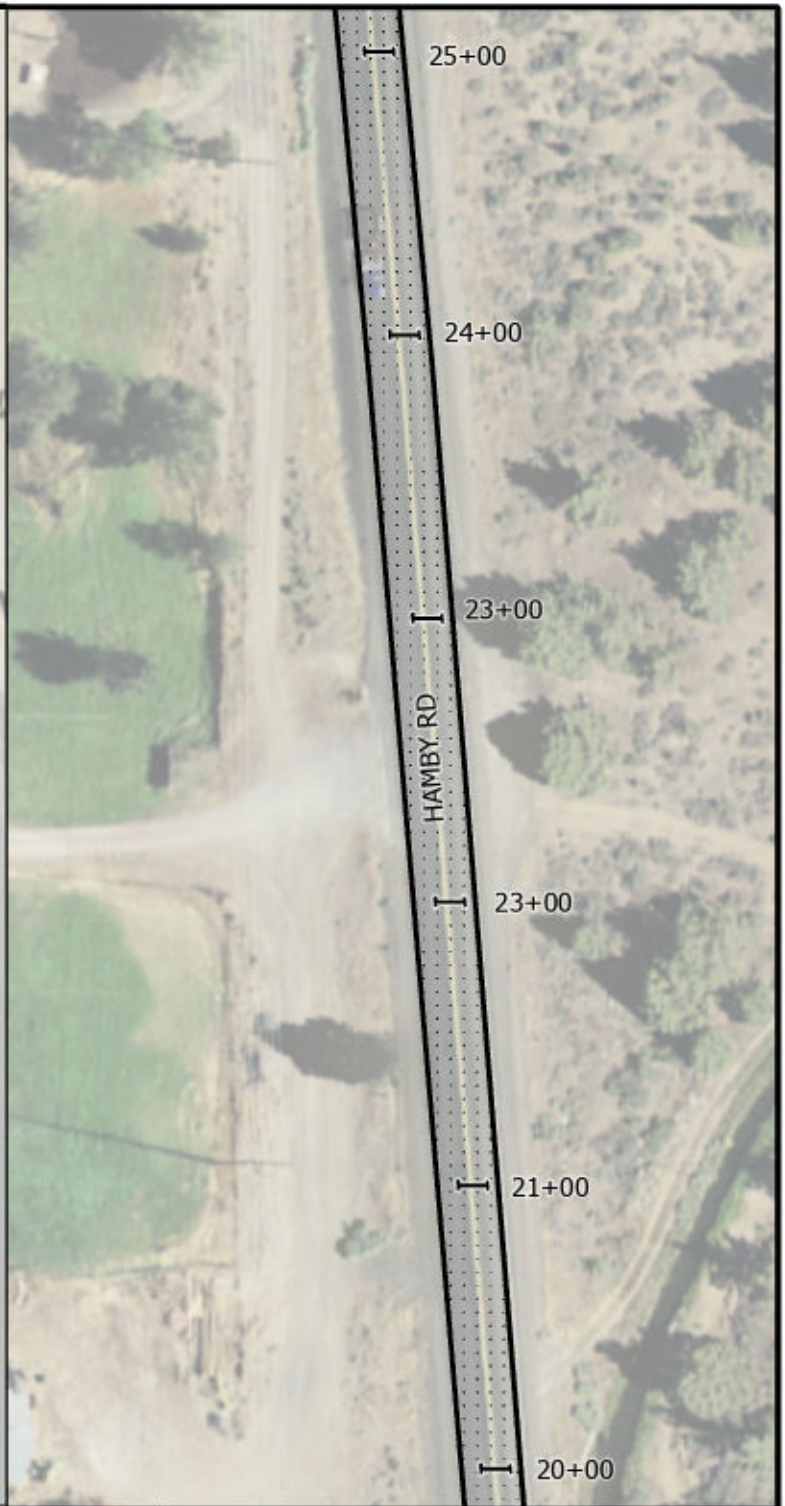
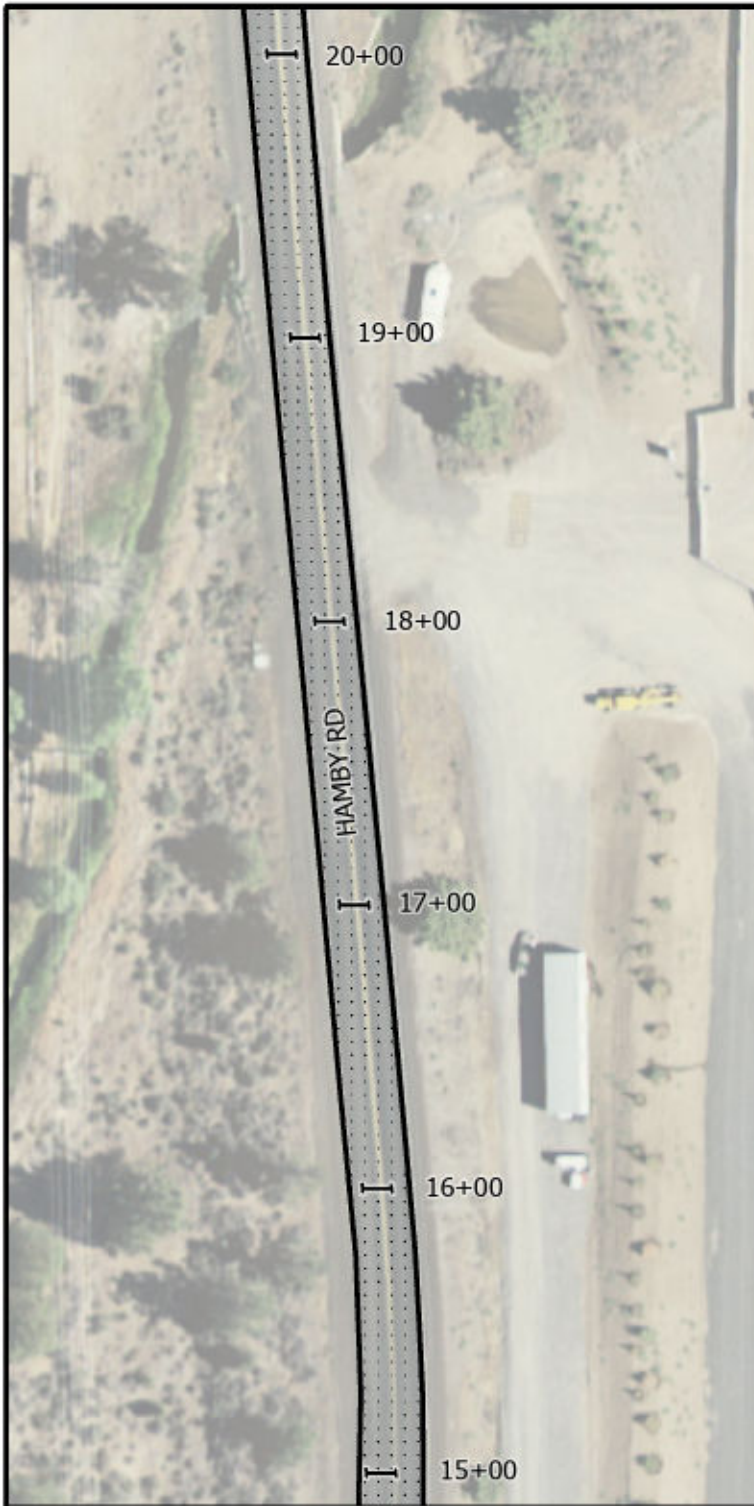

PLAN
NOT TO SCALE



LEGEND

 2" OVERLAY, FULL-WIDTH
(SEE TYPICAL SECTION, SHEET 2)

NOTES:

1. INSTALL THERMOPLASTIC CENTERLINE STRIPING AND RECESSED PAVEMENT MARKERS, TYPE D R-40
2. INSTALL THERMOPLASTIC FOG LINE, TYPE W-2



DESCHUTES COUNTY ROAD DEPARTMENT
61150 S.E. 27TH STREET
BEND, OR, 97702

PHONE: 541-388-6581 FAX: 541-888-2719

PAVING OF HAMBY RD:
US 20 to BUTLER MARKET RD

DRAFTER: R. PINKSTON

DATE: 5/6/2022

REVIEWED BY: C. SMITH

DATE: 5/6/2022

PLAN
STA 15+00 TO 25+00

SHEET NO.
7 of 23



PLAN
NOT TO SCALE



LEGEND

 2" OVERLAY, FULL-WIDTH
(SEE TYPICAL SECTION, SHEET 2)

NOTES:

1. INSTALL THERMOPLASTIC CENTERLINE STRIPING AND RECESSED PAVEMENT MARKERS, TYPE D R-40
2. INSTALL THERMOPLASTIC FOG LINE, TYPE W-2



DESCHUTES COUNTY ROAD DEPARTMENT
61150 S.E. 27TH STREET
BEND, OR, 97702

PHONE: 541-388-6581 FAX: 541-388-2719

PAVING OF HAMBY RD:
US 20 to BUTLER MARKET RD

DRAFTER: R. PINKSTON

DATE: 5/6/2022

REVIEWED BY: C. SMITH

DATE: 5/6/2022

PLAN
STA 25+00 TO 35+00



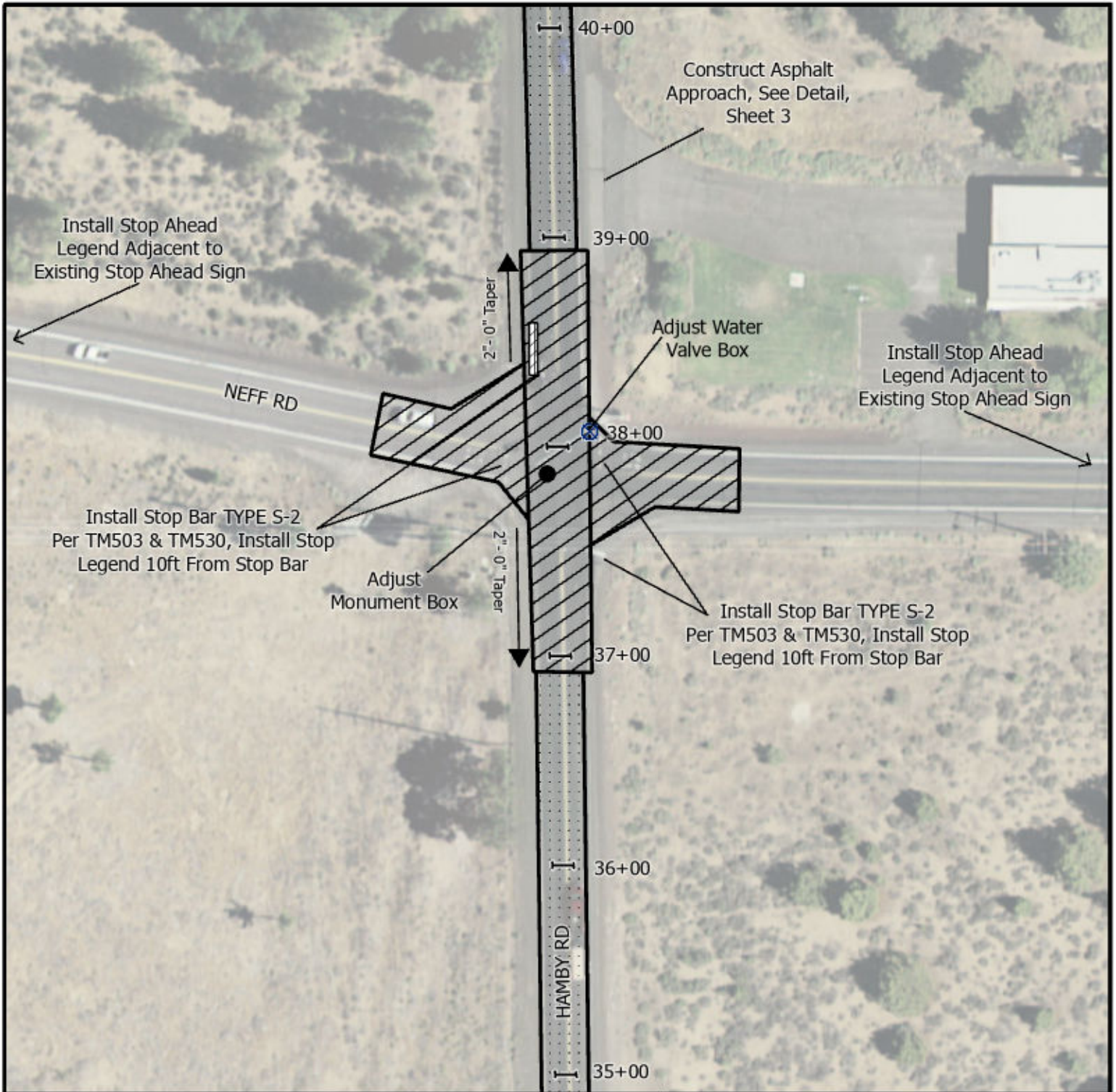

SHEET NO.
8 of 23



PLAN
NOT TO SCALE



LEGEND

-  WATER VALVE BOX
-  MONUMENT BOX
-  13" ACP REPAIR
(SEE REPAIR DETAIL, SHEET 4)
-  2"-0" COLD PLANE PAVEMENT
REMOVAL *Limits are approximate
(SEE DETAILS, SHEET 3)
-  2" OVERLAY, FULL-WIDTH
(SEE TYPICAL SECTION, SHEET 2)

NOTES:

1. INSTALL THERMOPLASTIC CENTERLINE STRIPING AND RECESSED PAVEMENT MARKERS, TYPE D R-40
2. INSTALL THERMOPLASTIC FOG LINE, TYPE W-2



DESCHUTES COUNTY ROAD DEPARTMENT
61150 S.E. 27TH STREET
BEND, OR, 97702

PHONE: 541-388-6581 FAX: 541-388-2719

PAVING OF HAMBY RD:
US 20 to BUTLER MARKET RD

DRAFTER: R. PINKSTON

DATE: 5/6/2022

REVIEWED BY: C. SMITH

DATE: 5/6/2022

PLAN
STA 35+00 TO 40+00

SHEET NO.
9 of 23

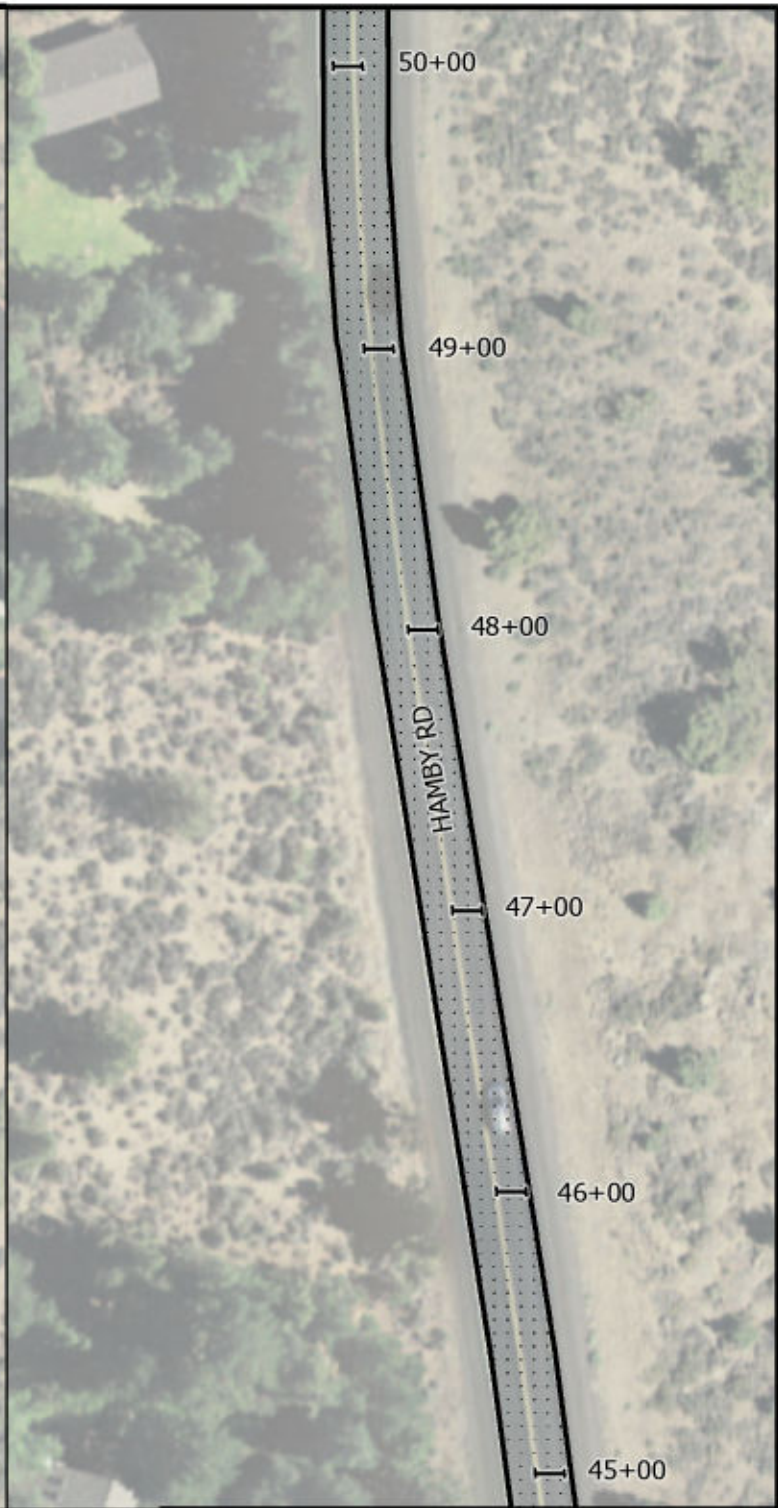
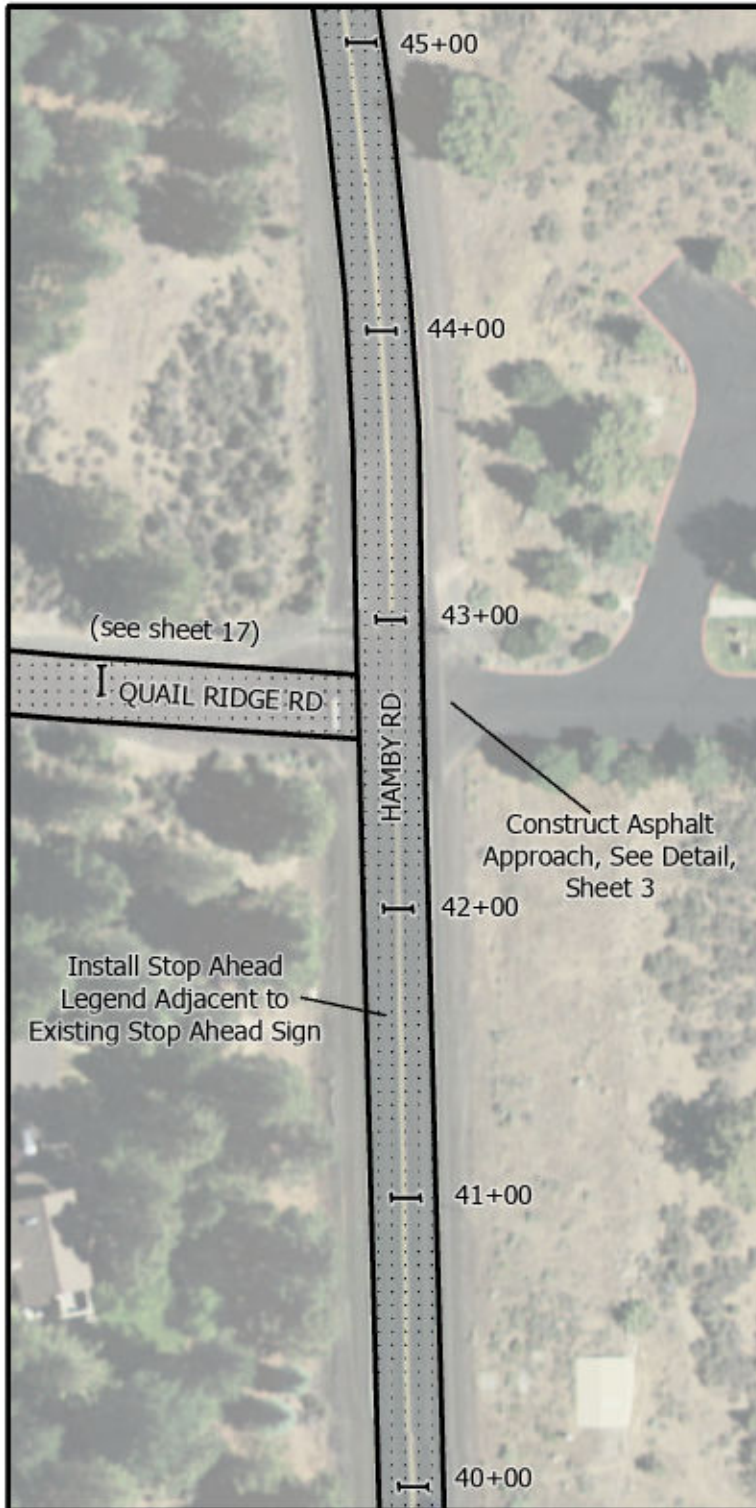

PLAN
NOT TO SCALE



LEGEND

 2" OVERLAY, FULL-WIDTH
(SEE TYPICAL SECTION, SHEET 2)

NOTES:

1. INSTALL THERMOPLASTIC CENTERLINE STRIPING AND RECESSED PAVEMENT MARKERS, TYPE D R-40
2. INSTALL THERMOPLASTIC FOG LINE, TYPE W-2



DESCHUTES COUNTY ROAD DEPARTMENT
61150 S.E. 27TH STREET
BEND, OR, 97702

PHONE: 541-388-6581 FAX: 541-388-2719

**PAVING OF HAMBY RD:
US 20 to BUTLER MARKET RD**

DRAFTER: R. PINKSTON

DATE: 5/6/2022

REVIEWED BY: C. SMITH

DATE: 5/6/2022

PLAN
STA 40+00 TO 50+00

SHEET NO.
10 of 23

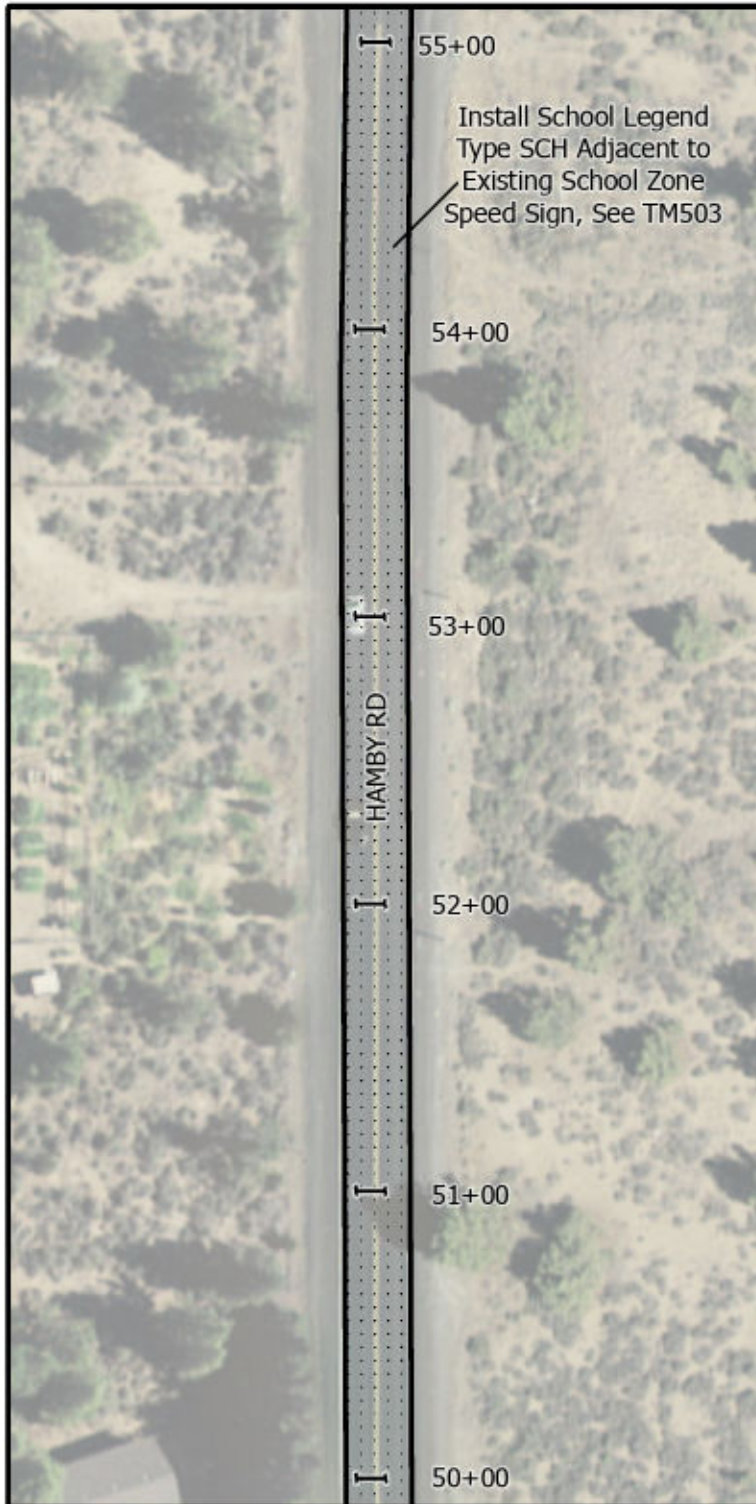

PLAN
NOT TO SCALE



LEGEND

 WATER VALVE BOX

 2" OVERLAY, FULL-WIDTH
(SEE TYPICAL SECTION, SHEET 2)

NOTES:

1. INSTALL THERMOPLASTIC CENTERLINE STRIPING AND RECESSED PAVEMENT MARKERS, TYPE D R-40
2. INSTALL THERMOPLASTIC FOG LINE, TYPE W-2



DESCHUTES COUNTY ROAD DEPARTMENT
61150 S.E. 27TH STREET
BEND, OR, 97702

PHONE: 541-388-6581 FAX: 541-388-2719

PAVING OF HAMBY RD:
US 20 to BUTLER MARKET RD

DRAFTER: R. PINKSTON

DATE: 5/6/2022

REVIEWED BY: C. SMITH

DATE: 5/6/2022

PLAN
STA 50+00 TO 60+00

SHEET NO.
11 of 23

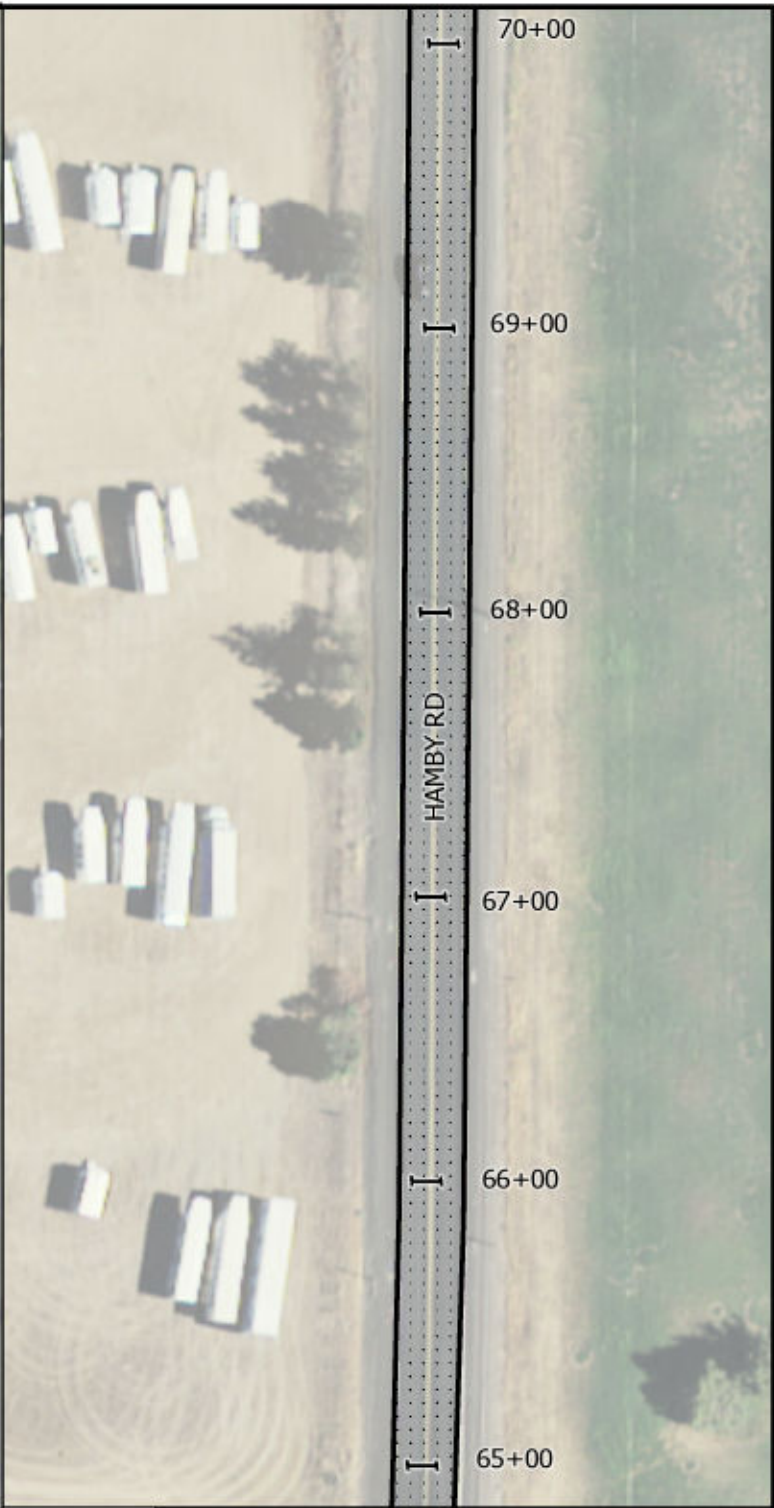
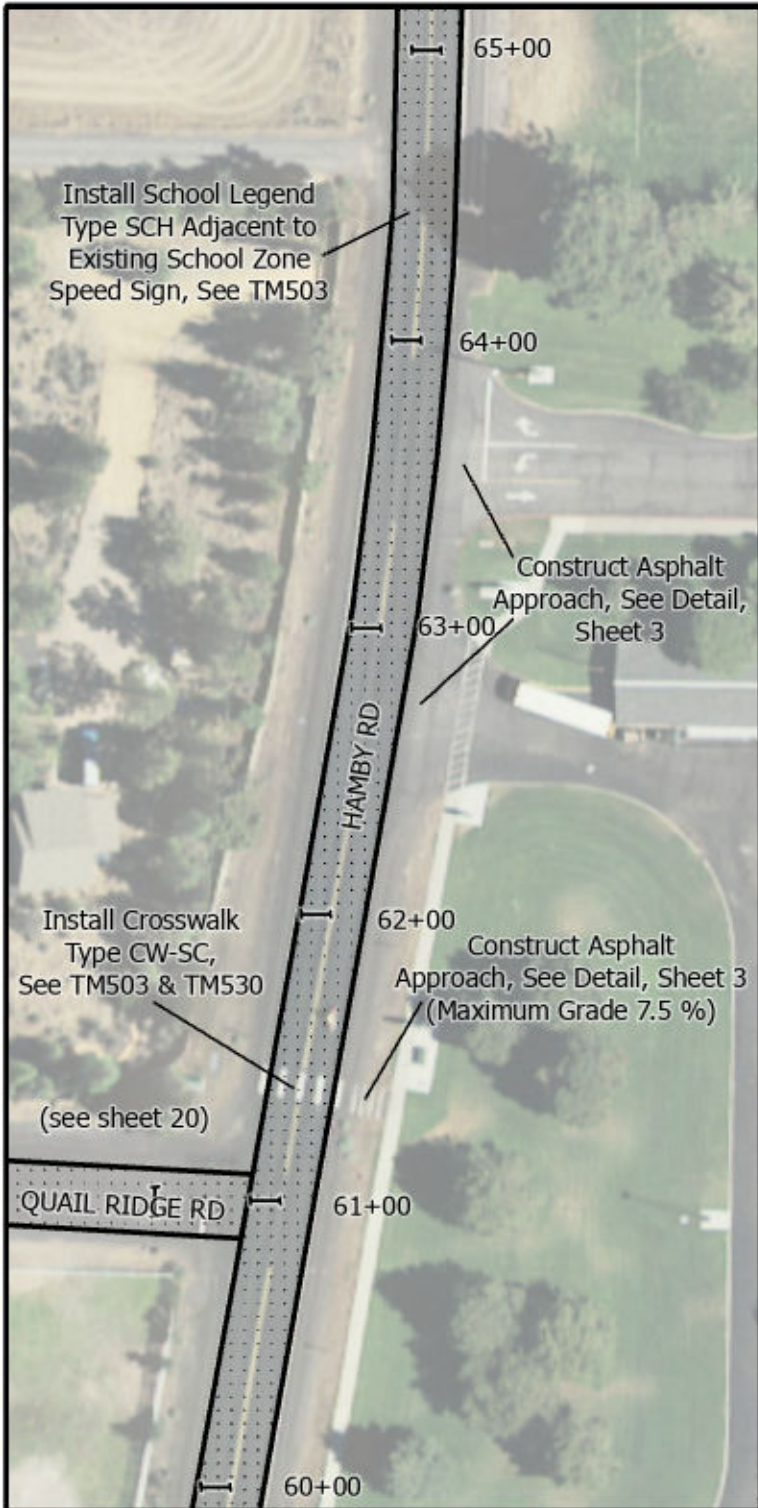

PLAN
NOT TO SCALE



LEGEND

 2" OVERLAY, FULL-WIDTH
(SEE TYPICAL SECTION, SHEET 2)

NOTES:

1. INSTALL THERMOPLASTIC CENTERLINE STRIPING AND RECESSED PAVEMENT MARKERS, TYPE D R-40
2. INSTALL THERMOPLASTIC FOG LINE, TYPE W-2



DESCHUTES COUNTY ROAD DEPARTMENT
61150 S.E. 27TH STREET
BEND, OR, 97702

PHONE: 541-388-6581 FAX: 541-388-2719

PAVING OF HAMBY RD:
US 20 to BUTLER MARKET RD

DRAFTER: R. PINKSTON DATE: 5/6/2022

REVIEWED BY: C. SMITH DATE: 5/6/2022

PLAN
STA 60+00 TO 70+00

SHEET NO.
12 of 23



PLAN
NOT TO SCALE



LEGEND

 WATER VALVE BOX

 2" OVERLAY, FULL-WIDTH
(SEE TYPICAL SECTION, SHEET 2)

NOTES:

1. INSTALL THERMOPLASTIC CENTERLINE STRIPING AND RECESSED PAVEMENT MARKERS, TYPE D R-40
2. INSTALL THERMOPLASTIC FOG LINE, TYPE W-2



DESCHUTES COUNTY ROAD DEPARTMENT
61150 S.E. 27TH STREET
BEND, OR, 97702

PHONE: 541-388-6581 FAX: 541-388-2719

PAVING OF HAMBY RD:
US 20 to BUTLER MARKET RD

DRAFTER: R. PINKSTON

DATE: 5/6/2022

REVIEWED BY: C. SMITH

DATE: 5/6/2022

PLAN
STA 70+00 TO 80+00

SHEET NO.
13 of 23



PLAN
NOT TO SCALE



LEGEND

 WATER VALVE BOX

 2" OVERLAY, FULL-WIDTH
(SEE TYPICAL SECTION, SHEET 2)

NOTES:

1. INSTALL THERMOPLASTIC CENTERLINE STRIPING AND RECESSED PAVEMENT MARKERS, TYPE D R-40
2. INSTALL THERMOPLASTIC FOG LINE, TYPE W-2



DESCHUTES COUNTY ROAD DEPARTMENT
61150 S.E. 27TH STREET
BEND, OR, 97702

PHONE: 541-388-6581 FAX: 541-388-2719

PAVING OF HAMBY RD:
US 20 to BUTLER MARKET RD

DRAFTER: R. PINKSTON DATE: 5/6/2022

REVIEWED BY: C. SMITH DATE: 5/6/2022

PLAN
STA 80+00 TO 90+00

SHEET NO.
14 of 23

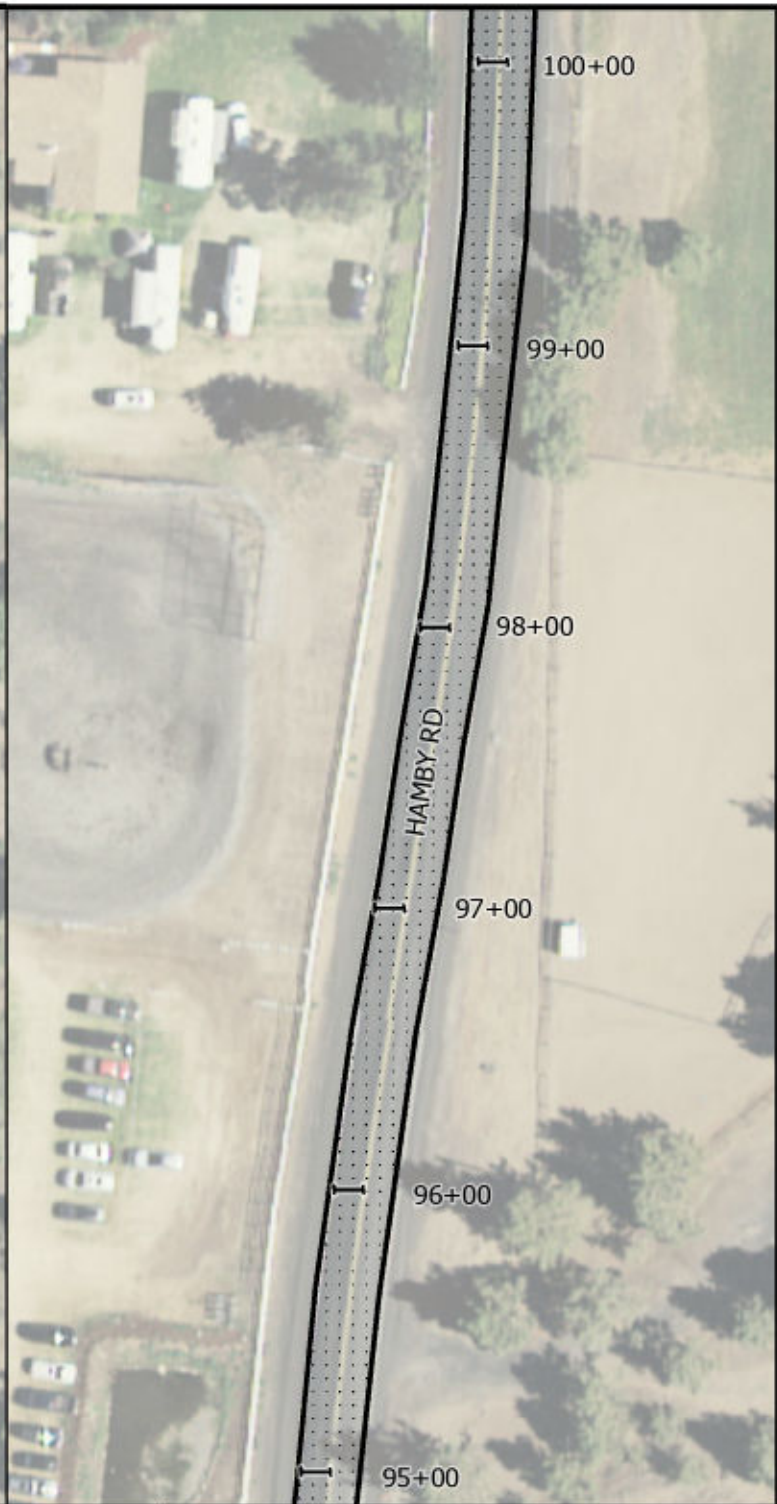
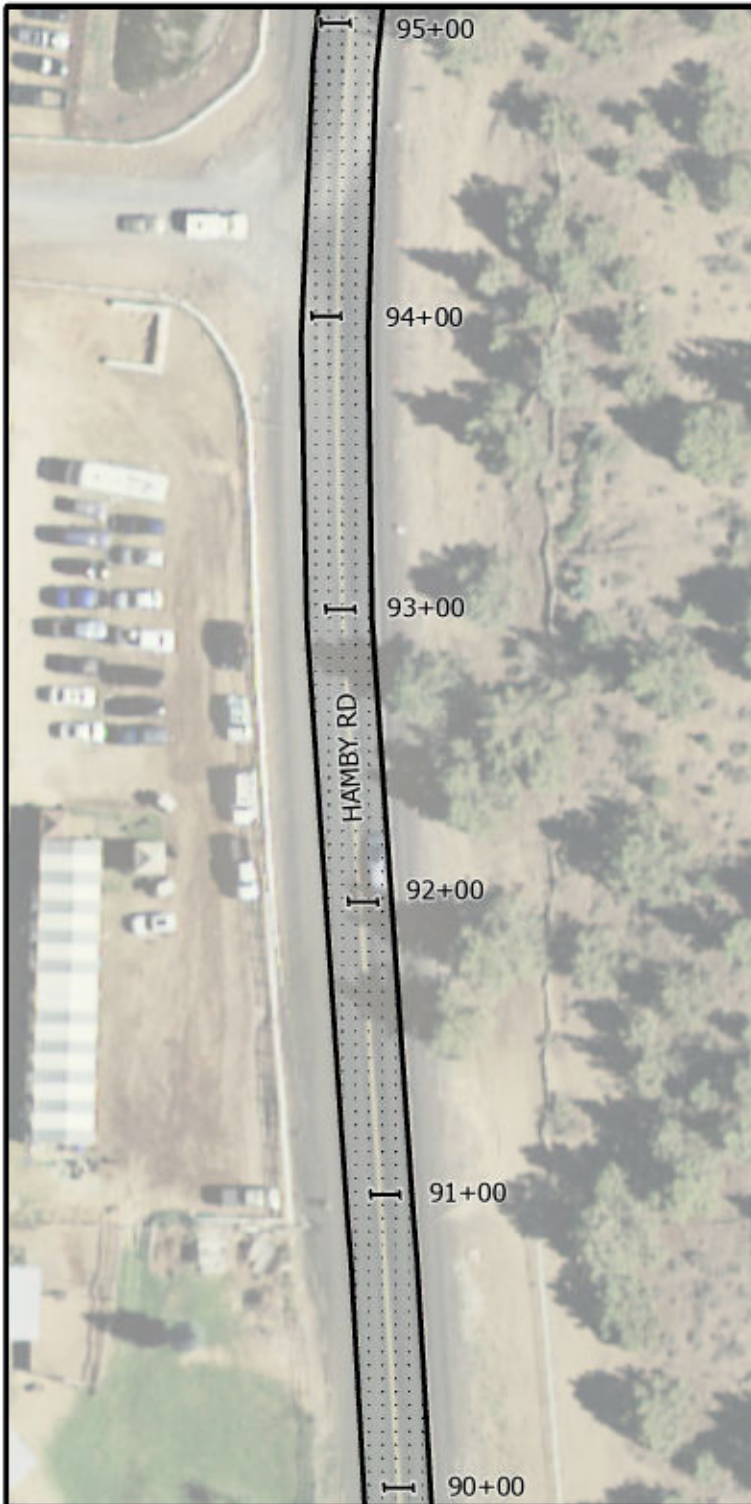

PLAN
NOT TO SCALE



LEGEND

 2" OVERLAY, FULL-WIDTH
(SEE TYPICAL SECTION, SHEET 2)

- NOTES:**
1. INSTALL THERMOPLASTIC CENTERLINE STRIPING AND RECESSED PAVEMENT MARKERS, TYPE D R-40
 2. INSTALL THERMOPLASTIC FOG LINE, TYPE W-2



DESCHUTES COUNTY ROAD DEPARTMENT
61150 S.E. 27TH STREET
BEND, OR, 97702

PHONE: 541-388-6581 FAX: 541-888-2719

PAVING OF HAMBY RD:
US 20 to BUTLER MARKET RD

DRAFTER: R. PINKSTON DATE: 5/6/2022

REVIEWED BY: C. SMITH DATE: 5/6/2022

PLAN
STA 90+00 TO 100+00

SHEET NO.
15 of 23



PLAN
NOT TO SCALE



LEGEND

 WATER VALVE BOX

 2" OVERLAY, FULL-WIDTH
(SEE TYPICAL SECTION, SHEET 2)

NOTES:

1. INSTALL THERMOPLASTIC CENTERLINE STRIPING AND RECESSED PAVEMENT MARKERS, TYPE D R-40
2. INSTALL THERMOPLASTIC FOG LINE, TYPE W-2



DESCHUTES COUNTY ROAD DEPARTMENT
61150 S.E. 27TH STREET
BEND, OR, 97702

PHONE: 541-388-6581 FAX: 541-888-2719

PAVING OF HAMBY RD:
US 20 to BUTLER MARKET RD

DRAFTER: R. PINKSTON DATE: 5/6/2022

REVIEWED BY: C. SMITH DATE: 5/6/2022

PLAN
STA 100+00 TO 110+00

SHEET NO.
16 of 23

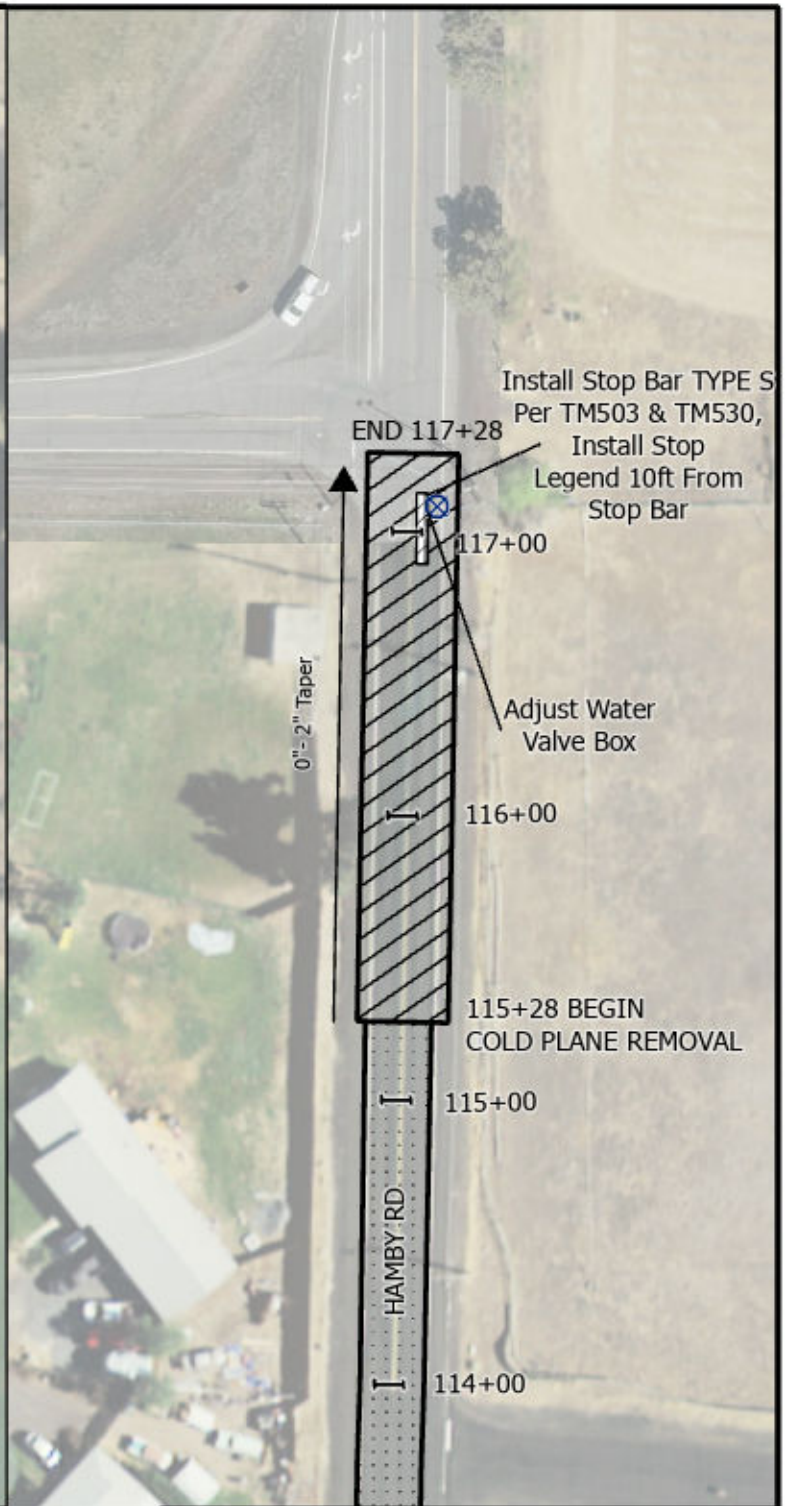
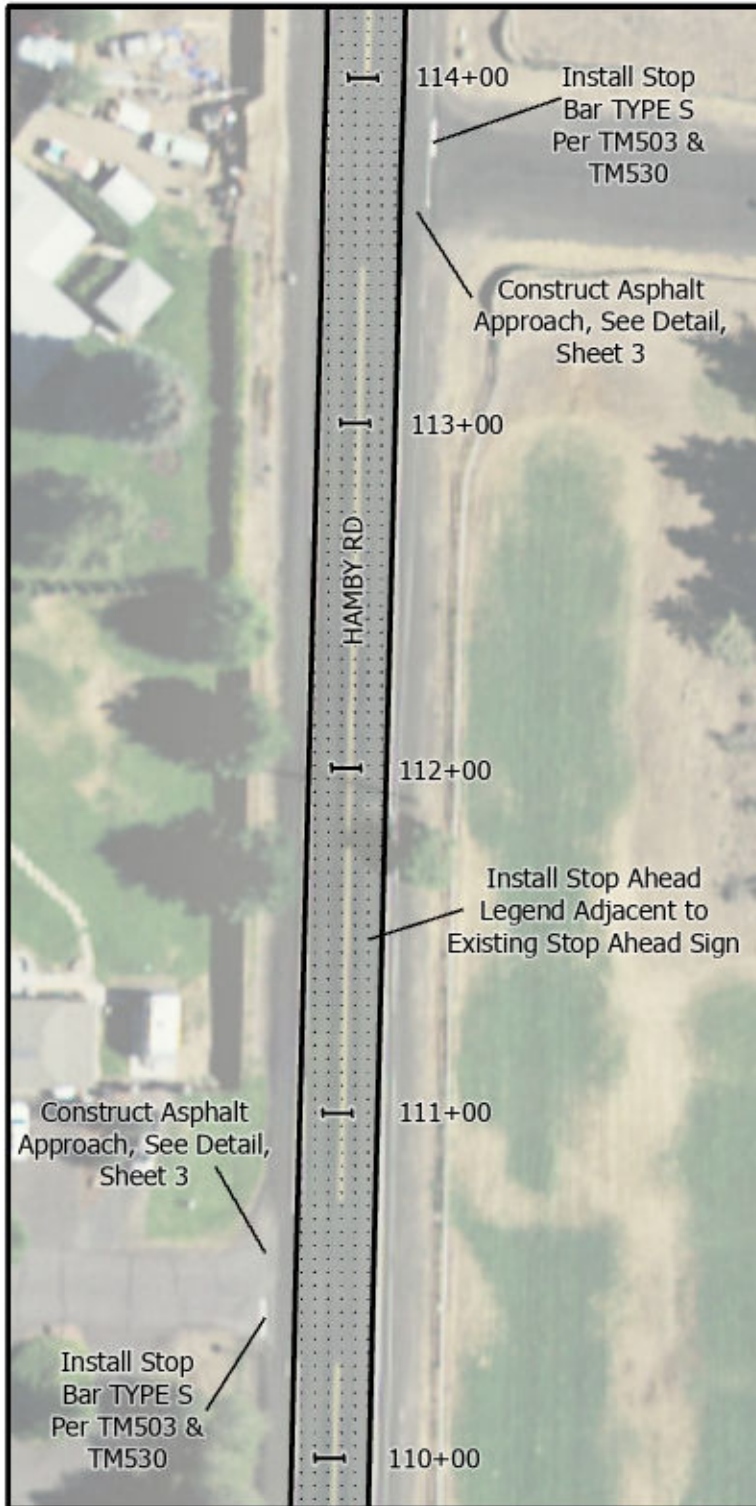

PLAN
NOT TO SCALE



LEGEND

WATER VALVE BOX

ACP REPAIR

2"-0" COLD PLANE PAVEMENT REMOVAL

2" OVERLAY, FULL-WIDTH (SEE TYPICAL SECTION, SHEET 2)

NOTES:

1. INSTALL THERMOPLASTIC CENTERLINE STRIPING AND RECESSED PAVEMENT MARKERS, TYPE D R-40
2. INSTALL THERMOPLASTIC FOG LINE, TYPE W-2



DESCHUTES COUNTY ROAD DEPARTMENT
61150 S.E. 27TH STREET
BEND, OR, 97702

PHONE: 541-388-6581 FAX: 541-388-2719

PAVING OF HAMBY RD:
US 20 to BUTLER MARKET RD

DRAFTER: R. PINKSTON

DATE: 5/6/2022

REVIEWED BY: C. SMITH

DATE: 5/6/2022

PLAN
STA 110+00 TO
END OF HAMBY RD

SHEET NO.
17 of 23

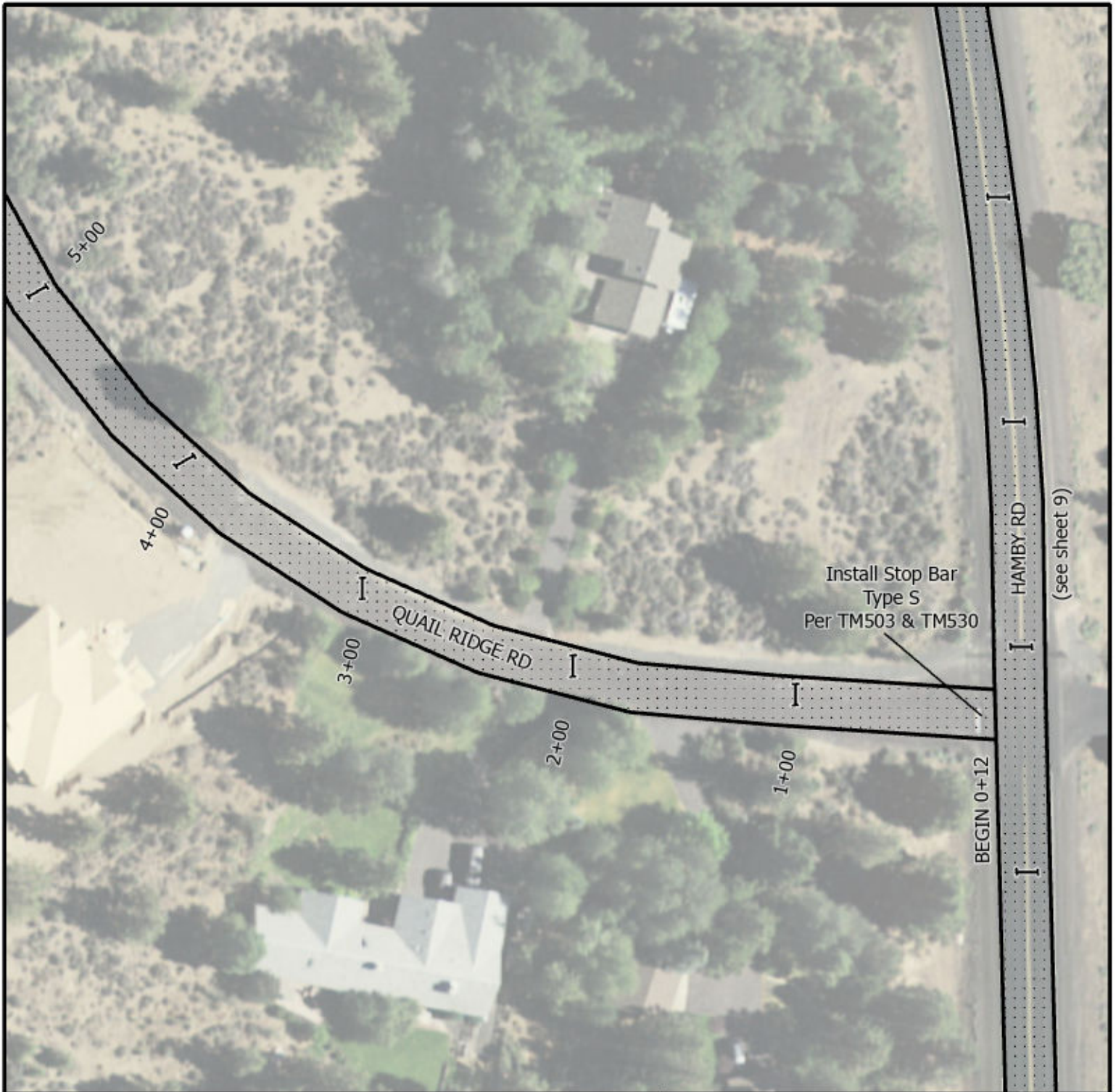

PLAN
NOT TO SCALE



LEGEND

 2" OVERLAY, FULL-WIDTH
(SEE TYPICAL SECTION, SHEET 2)



DESCHUTES COUNTY ROAD DEPARTMENT
61150 S.E. 27TH STREET
BEND, OR, 97702

PHONE: 541-388-6581 FAX: 541-388-2719

PAVING OF HAMBY RD:
US 20 to BUTLER MARKET RD

DRAFTER: R. PINKSTON DATE: 5/6/2022

REVIEWED BY: C. SMITH DATE: 5/6/2022

PLAN
BEGIN QUAIL RIDGE RD
STA 0+12 TO 5+00

SHEET NO.
18 of 23

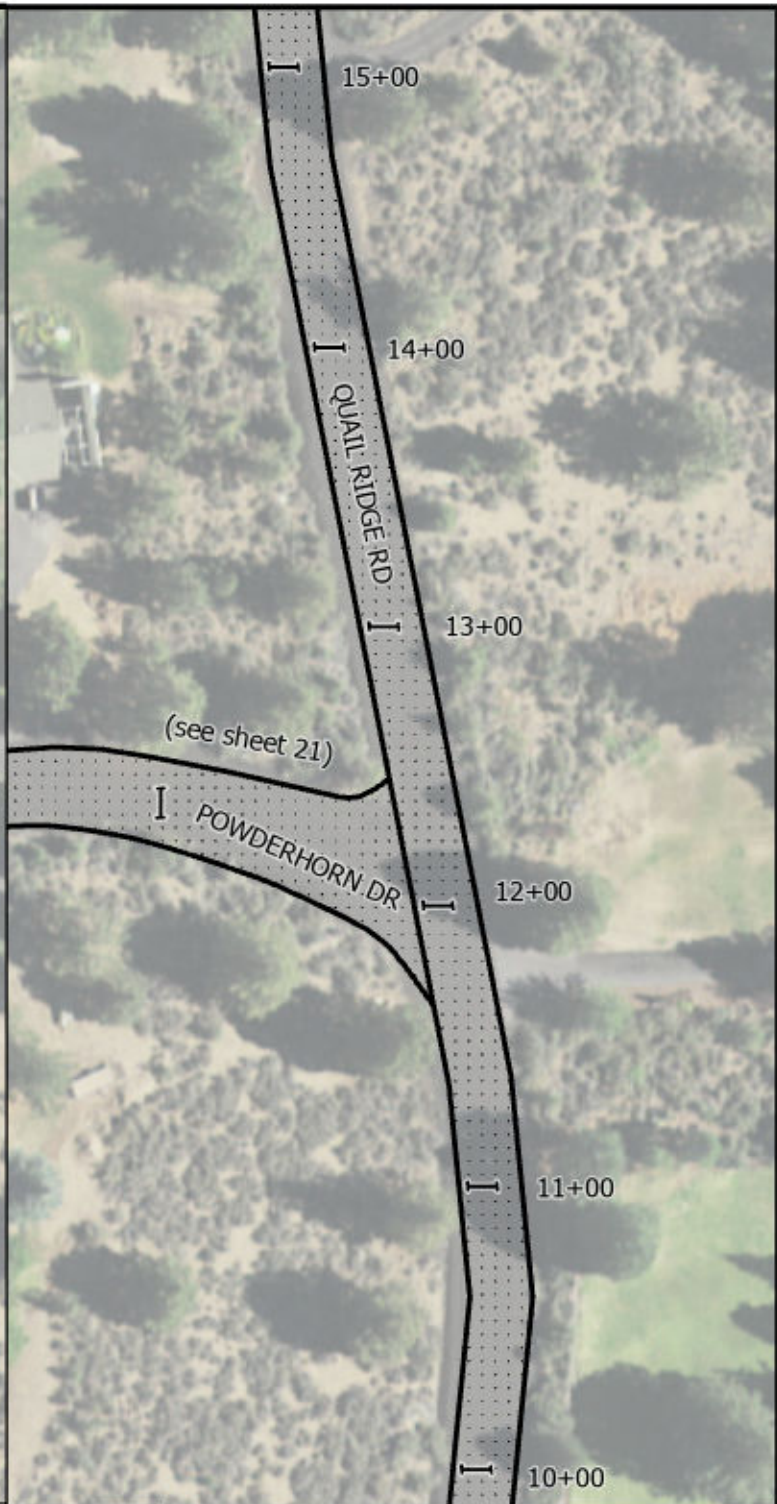
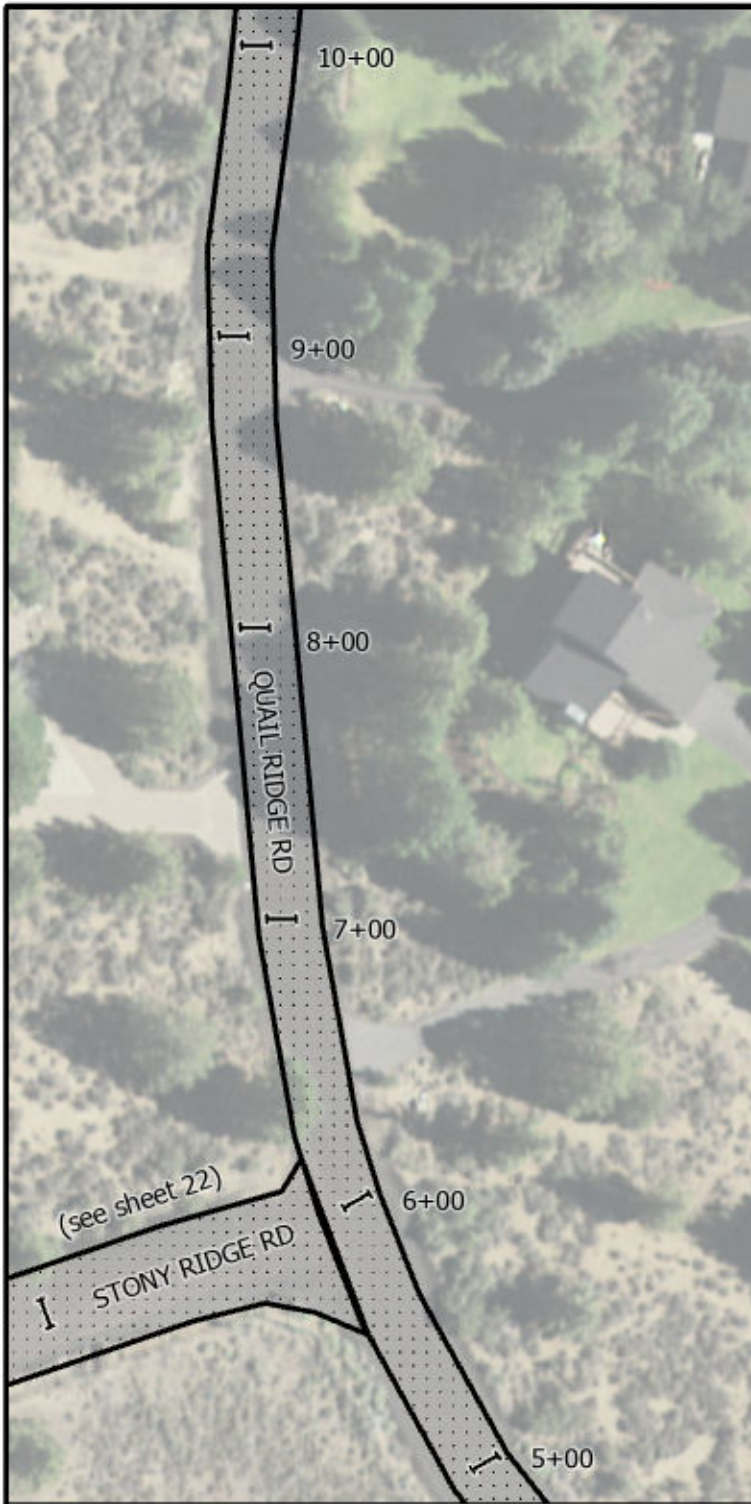

PLAN
NOT TO SCALE



LEGEND

 2" OVERLAY, FULL-WIDTH
(SEE TYPICAL SECTION, SHEET 2)



DESCHUTES COUNTY ROAD DEPARTMENT
61150 S.E. 27TH STREET
BEND, OR, 97702

PHONE: 541-388-6581 FAX: 541-388-2719

PAVING OF HAMBY RD:
US 20 to BUTLER MARKET RD

DRAFTER: R. PINKSTON

DATE: 5/6/2022

REVIEWED BY: C. SMITH

DATE: 5/6/2022

PLAN
STA 5+00 TO 15+00

SHEET NO.
19 of 23



PLAN
NOT TO SCALE



LEGEND

 2" OVERLAY, FULL-WIDTH
(SEE TYPICAL SECTION, SHEET 2)



DESCHUTES COUNTY ROAD DEPARTMENT
61150 S.E. 27TH STREET
BEND, OR, 97702

PHONE: 541-388-6581 FAX: 541-388-2719

PAVING OF HAMBY RD:
US 20 to BUTLER MARKET RD

DRAFTER: R. PINKSTON DATE: 5/6/2022

REVIEWED BY: C. SMITH DATE: 5/6/2022

PLAN
STA 15+00 TO 20+00

SHEET NO.
20 of 23



PLAN
NOT TO SCALE



LEGEND

 2" OVERLAY, FULL-WIDTH
(SEE TYPICAL SECTION, SHEET 2)



DESCHUTES COUNTY ROAD DEPARTMENT
61150 S.E. 27TH STREET
BEND, OR, 97702

PHONE: 541-388-6581 FAX: 541-388-2719

PAVING OF HAMBY RD:
US 20 to BUTLER MARKET RD

DRAFTER: R. PINKSTON

DATE: 5/6/2022

REVIEWED BY: C. SMITH

DATE: 5/6/2022

PLAN
STA 20+00 TO
END OF QUAIL RIDGE RD

SHEET NO.
21 of 23

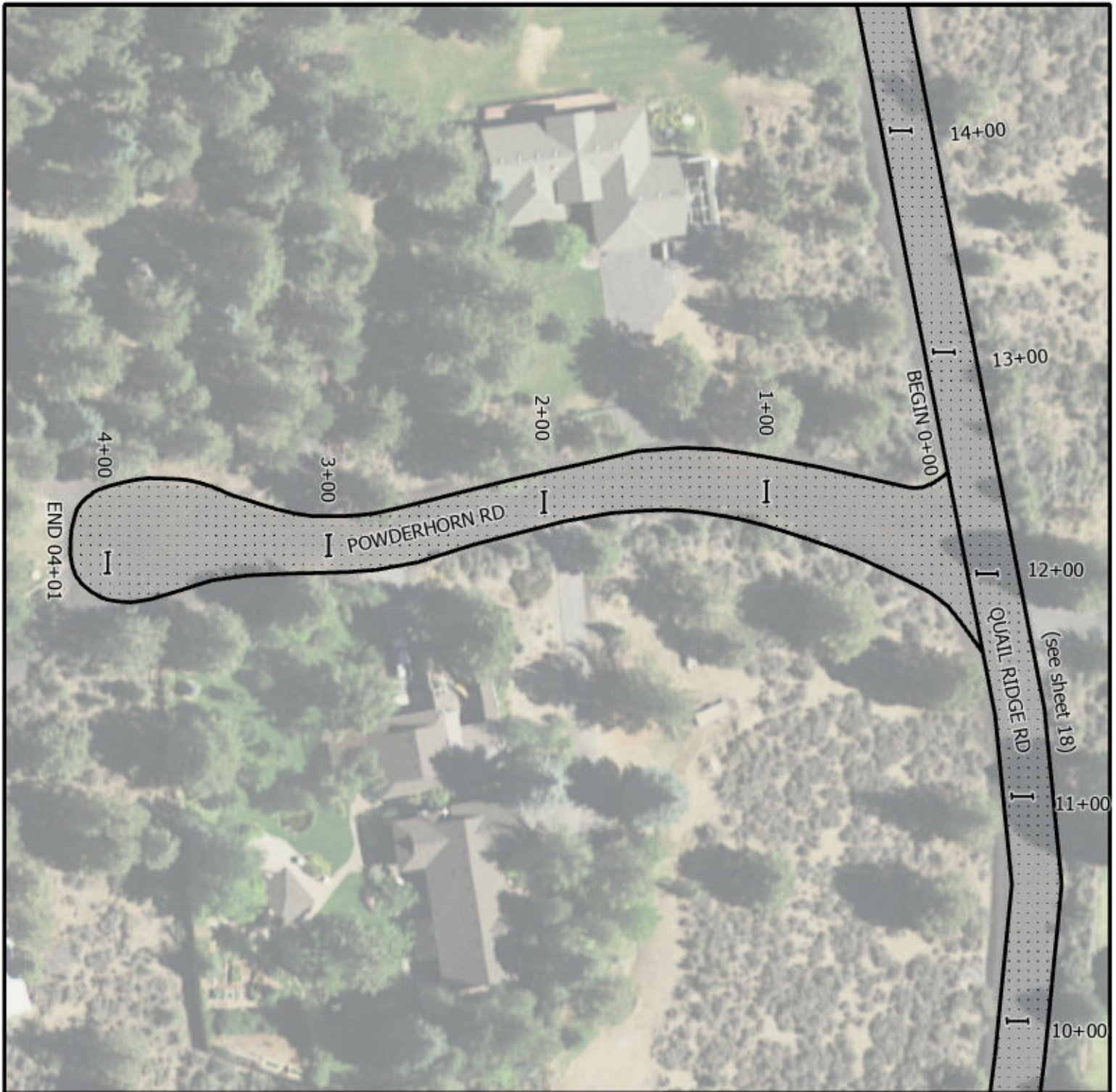

PLAN
NOT TO SCALE



LEGEND

 2" OVERLAY, FULL-WIDTH
(SEE TYPICAL SECTION, SHEET 2)



DESCHUTES COUNTY ROAD DEPARTMENT
61150 S.E. 27TH STREET
BEND, OR, 97702

PHONE: 541-388-6581 FAX: 541-388-2719

PAVING OF HAMBY RD:
US 20 to BUTLER MARKET RD

DRAFTER: R. PINKSTON

DATE: 5/6/2022

REVIEWED BY: C. SMITH

DATE: 5/6/2022

PLAN
STA 0+00 TO END
POWDERHORN DR

SHEET NO.
22 of 23

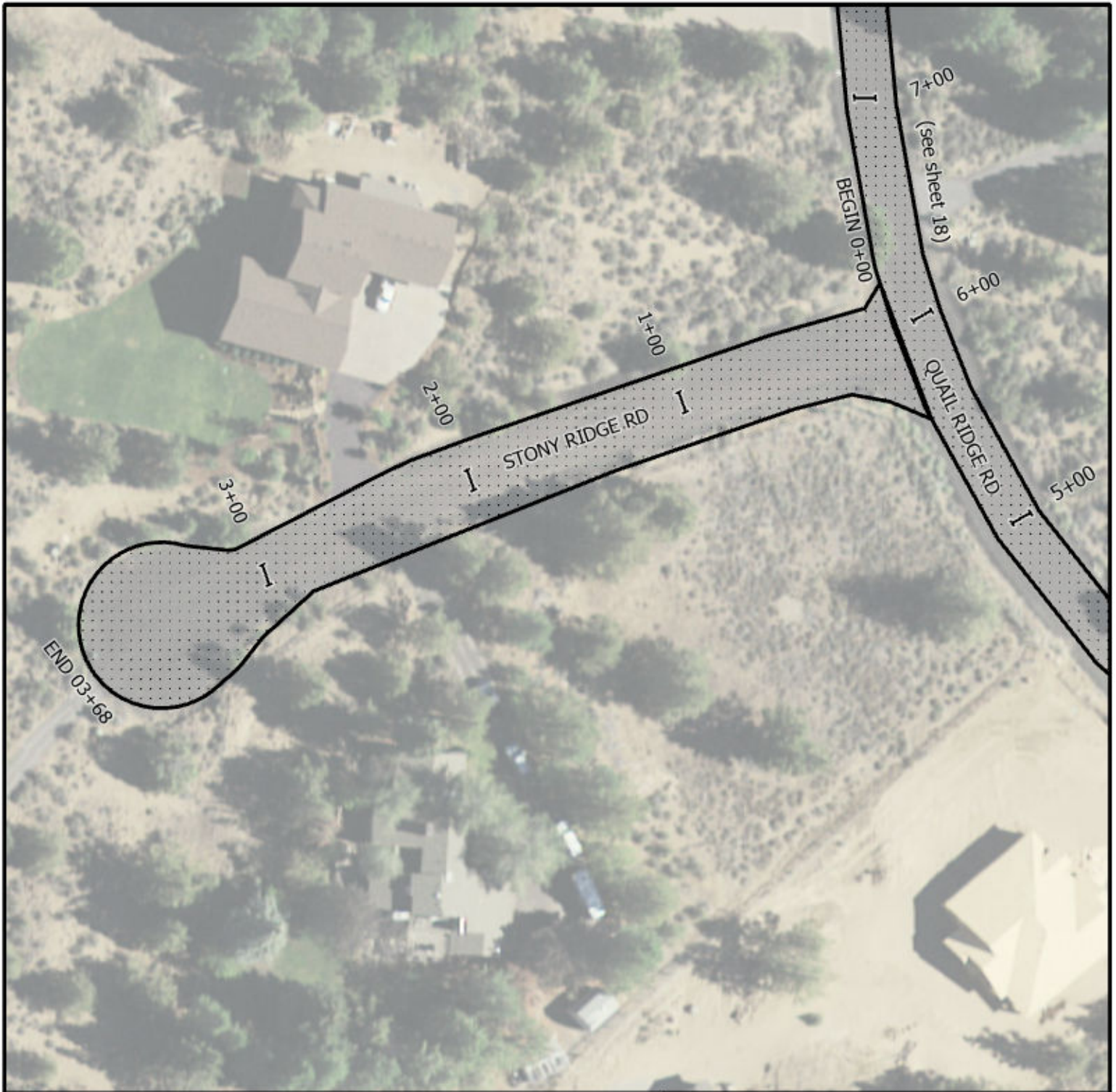

PLAN
NOT TO SCALE



LEGEND

 2" OVERLAY, FULL-WIDTH
(SEE TYPICAL SECTION, SHEET 2)



DESCHUTES COUNTY ROAD DEPARTMENT
61150 S.E. 27TH STREET
BEND, OR, 97702

PHONE: 541-388-6581 FAX: 541-388-2719

PAVING OF HAMBY RD:
US 20 to BUTLER MARKET RD

DRAFTER: R. PINKSTON DATE: 5/6/2022

REVIEWED BY: C. SMITH DATE: 5/6/2022

PLAN
STA 0+00 TO END
STONY RIDGE RD

SHEET NO.
23 of 23

rd610.dgn 20-JUL-2020

RD610

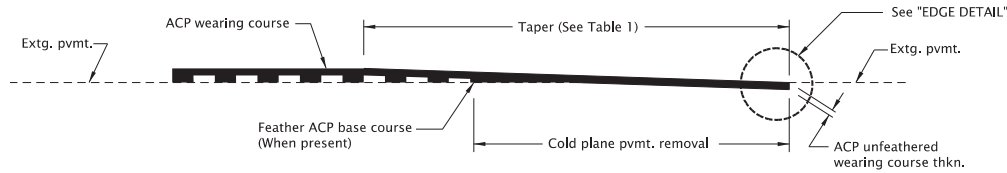

METHOD A *

* See project plans for method.

TABLE 1	
TAPER LENGTHS	
Posted Speed	Taper Length
< 45 mph	1" per 50'
≥ 45 mph	1" per 100'

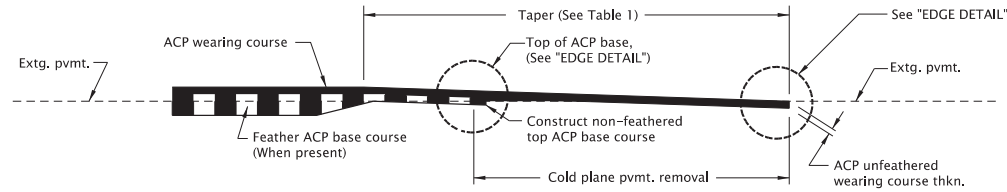

METHOD B *

**ACP PAVEMENT MATCH AT PROJECT ENDS
OR BRIDGE ENDS WHEN NOT OVERLAYING THE BRIDGE**

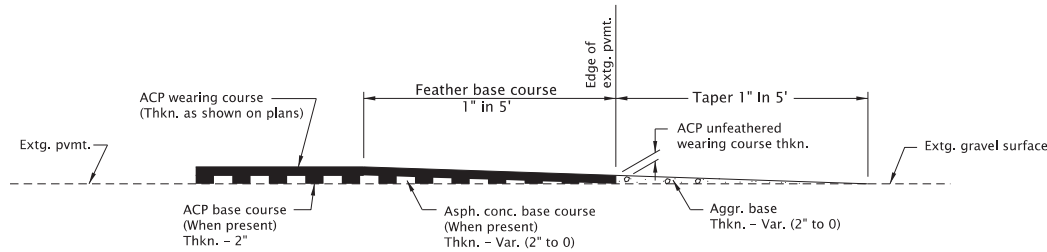
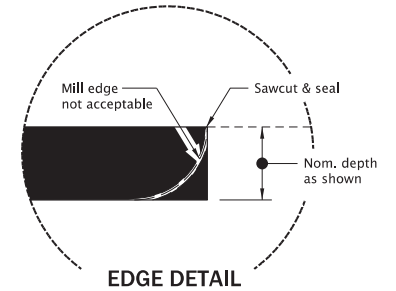

**METHOD OF FEATHERING ACP PAVEMENT
AT GRAVEL APPROACHES**

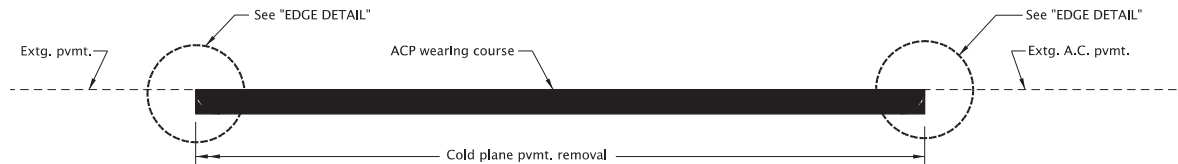

METHOD OF MATCHING EXTG. ACP INLAY SURFACING
(Inlay to extg. asphalt conc. pvmt.)

CALC. BOOK NO. N/A SDR DATE 25-JUL-2017









NOTE: All material and workmanship shall be in accordance with the current Oregon Standard Specifications

OREGON STANDARD DRAWINGS
ASPHALT CONCRETE
PAVEMENT (ACP)
DETAILS

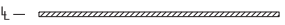
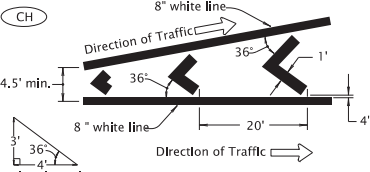
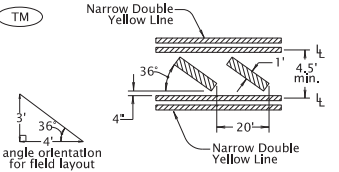
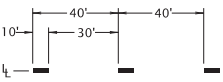
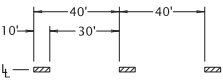
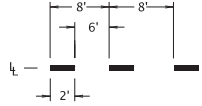
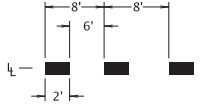
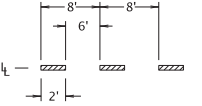
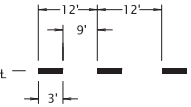
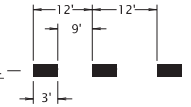
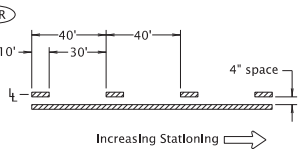
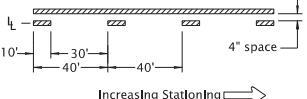
2021

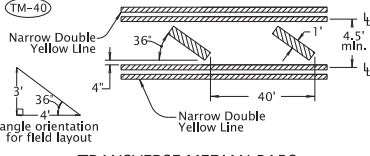
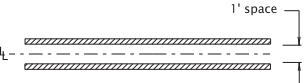
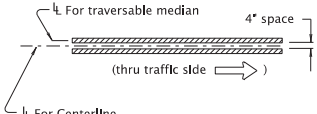
DATE	REVISION DESCRIPTION

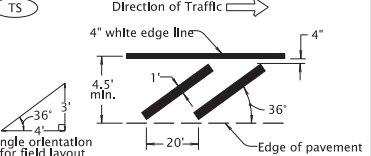
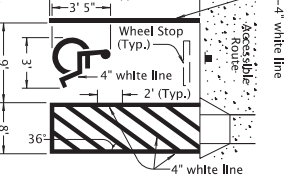
The selection and use of this Standard Drawing, while designed in accordance with generally accepted engineering principles and practices, is the sole responsibility of the user and should not be used without consulting a Registered Professional Engineer.

<p>(W)</p>  <p>4" WHITE LINE</p>	<p>(W-2)</p>  <p>8" WHITE LINE</p>	<p>(Y)</p>  <p>4" YELLOW LINE</p>	<p>(CH)</p>  <p>CHEVRON BARS 1" WHITE BARS AT 20' SPACING</p>	<p>(TM)</p>  <p>TRANSVERSE MEDIAN BARS 1" YELLOW BARS AT 20' SPACING</p>																																								
<p>(WB)</p>  <p>4" WHITE BROKEN LINE</p>	<p>(YB)</p>  <p>4" YELLOW BROKEN LINE</p>	<p>(WD)</p>  <p>4" WHITE DOTTED LINE For lane extensions</p>	<p>(WD-2)</p>  <p>8" WHITE DOTTED LINE For lane extensions and bike lane extensions</p>	<p>(YD)</p>  <p>4" YELLOW DOTTED LINE For lane extensions</p>																																								
<p>(DLL)</p>  <p>4" WHITE DOTTED LANE LINE For lane lines in acceleration/deceleration lanes</p>	<p>(DLL-2)</p>  <p>8" WHITE DOTTED LANE LINE For lane lines in drop lanes</p>	<p>(NPR)</p>  <p>NO-PASS RIGHT 4" YELLOW LINES</p>	<p>(NPL)</p>  <p>NO-PASS LEFT 4" YELLOW LINES</p>	<p>(TWL)</p>  <p>TWO-WAY LEFT TURN 4" YELLOW LINES</p>																																								
<p>(TM-40)</p>  <p>TRANSVERSE MEDIAN BARS 1" YELLOW BARS AT 40' SPACING For use at painted medians where distance between left turn refuges exceeds 200'</p>	<p>(D)</p>  <p>DOUBLE NO-PASS TWO 4" YELLOW LINES</p>	<p>(ND)</p>  <p>NARROW DOUBLE NO-PASS TWO 4" YELLOW LINES</p>	<p>(NDW)</p>  <p>NARROW DOUBLE NO-LANE CHANGE TWO 4" WHITE LINES</p>	<p>(TS)</p>  <p>TRANSVERSE SHOULDER BARS 1" WHITE BARS AT 20' SPACING</p>																																								
<p>(HC)</p>  <p>DISABLED PARKING DETAIL (white)</p>	<p>(YLD)</p>  <p>YIELD LINE (white)</p>	<p>(BYLD)</p>  <p>BICYCLE YIELD LINE (white)</p>	<table border="1"> <tr> <td colspan="2">CALC. BOOK NO. ____ N/A ____</td> <td colspan="2">SDR DATE ____ 02/01/2020 ____</td> </tr> <tr> <td colspan="4">NOTE: All material and workmanship shall be in accordance with the current Oregon Standard Specifications.</td> </tr> <tr> <td colspan="4" style="text-align: center;">OREGON STANDARD DRAWINGS</td> </tr> <tr> <td colspan="4" style="text-align: center;">PAVEMENT MARKING</td> </tr> <tr> <td colspan="4" style="text-align: center;">STANDARD DETAIL BLOCKS</td> </tr> <tr> <td colspan="4" style="text-align: center;">2021</td> </tr> <tr> <td>DATE</td> <td colspan="3">REVISION DESCRIPTION</td> </tr> <tr> <td>07/2020</td> <td colspan="3">Changed Min. widths for CH, TM, TM-40, and TS</td> </tr> <tr> <td> </td> <td colspan="3"> </td> </tr> <tr> <td> </td> <td colspan="3"> </td> </tr> </table>		CALC. BOOK NO. ____ N/A ____		SDR DATE ____ 02/01/2020 ____		NOTE: All material and workmanship shall be in accordance with the current Oregon Standard Specifications.				OREGON STANDARD DRAWINGS				PAVEMENT MARKING				STANDARD DETAIL BLOCKS				2021				DATE	REVISION DESCRIPTION			07/2020	Changed Min. widths for CH, TM, TM-40, and TS										
CALC. BOOK NO. ____ N/A ____		SDR DATE ____ 02/01/2020 ____																																										
NOTE: All material and workmanship shall be in accordance with the current Oregon Standard Specifications.																																												
OREGON STANDARD DRAWINGS																																												
PAVEMENT MARKING																																												
STANDARD DETAIL BLOCKS																																												
2021																																												
DATE	REVISION DESCRIPTION																																											
07/2020	Changed Min. widths for CH, TM, TM-40, and TS																																											

← Direction Of Traffic, Increasing Stationing Or Thru Traffic Side







⊥ — Lane line dimensions are shown on the striping plans

LEGEND

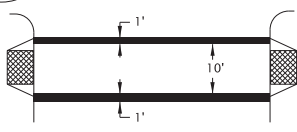
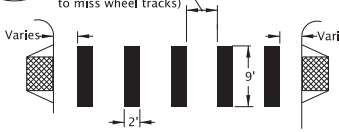
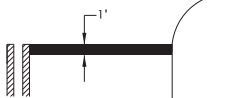
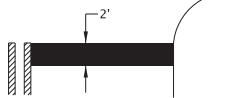
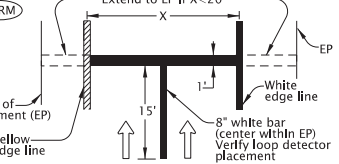
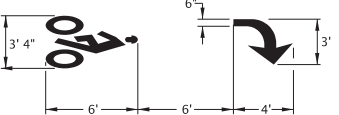
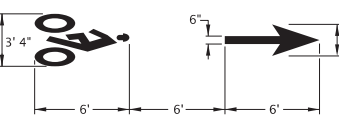
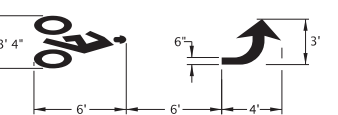
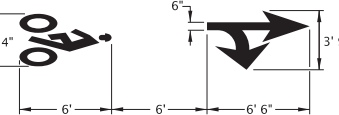
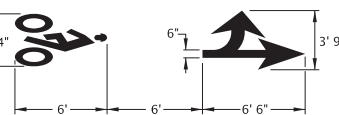
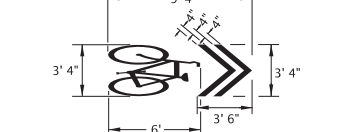
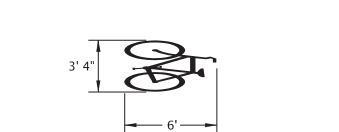
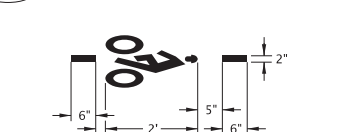
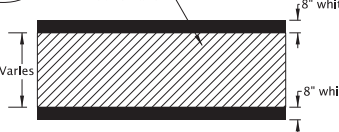
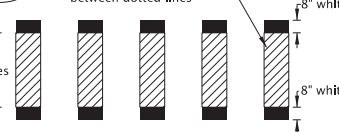
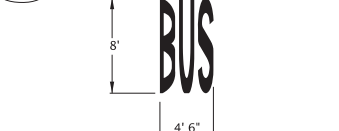
The selection and use of this Standard Drawing, while designed in accordance with generally accepted engineering principles and practices, is the sole responsibility of the user and should not be used without consulting a Registered Professional Engineer.

<p>TRANSVERSE MEDIAN BAR SUBSTITUTION BUTTON</p>	<p>YELLOW BROKEN LINE SUPPLEMENTATION REFLECTORS WITH 4" YELLOW BROKEN LINE</p>	<p>YELLOW BROKEN LINE SUPPLEMENTATION REFLECTORS WITH 4" YELLOW BROKEN LINE</p>	<p>WHITE BROKEN LINE SUPPLEMENTATION REFLECTORS WITH 4" WHITE BROKEN LINE</p>	<p>WHITE BROKEN LINE SUPPLEMENTATION REFLECTORS WITH 4" WHITE BROKEN LINE</p>
<p>WHITE DOTTED LANE LINE SUPPLEMENTATION REFLECTORS WITH 4" WHITE DOTTED LANE LINE</p>	<p>WIDE DOTTED LANE LINE SUPPLEMENTATION REFLECTORS WITH 8" WHITE DOTTED LANE LINE</p>	<p>WIDE DOTTED LANE LINE SUPPLEMENTATION REFLECTORS WITH 8" WHITE DOTTED LANE LINE</p>	<p>CHANNELIZING LINE POSITIONING GUIDE REFLECTORS WITH 8" WHITE LINE</p>	<p>CHANNELIZING LINE POSITIONING GUIDE REFLECTORS WITH 8" WHITE LINE</p>
<p>CHANNELIZING LANE LINE POSITIONING GUIDE REFLECTORS WITH 8" WHITE LINE</p>	<p>CHANNELIZING LINE SUPPLEMENTATION REFLECTORS WITH 8" WHITE LINE</p>	<p>CHANNELIZING LINE SUPPLEMENTATION REFLECTORS WITH 8" WHITE LINE</p>	<p>NARROW DOUBLE YELLOW POSITIONING GUIDE REFLECTORS WITH TWO 4" YELLOW LINES</p>	<p>NARROW DOUBLE YELLOW POSITIONING GUIDE REFLECTORS WITH TWO 4" YELLOW LINES</p>
<p>DOUBLE NO-PASS POSITIONING GUIDE REFLECTORS WITH TWO 4" YELLOW LINES</p>	<p>DOUBLE NO-PASS POSITIONING GUIDE REFLECTORS WITH TWO 4" YELLOW LINES</p>	<p>YELLOW LINE POSITIONING GUIDE REFLECTORS WITH 4" YELLOW LINE</p>	<p>YELLOW LINE POSITIONING GUIDE REFLECTORS WITH 4" YELLOW LINE</p>	<p>NO-PASS LEFT POSITIONING GUIDE REFLECTORS WITH 4" YELLOW LINES</p>
<p>NO-PASS RIGHT POSITIONING GUIDE REFLECTORS WITH 4" YELLOW LINES</p>	<p>TWO WAY LEFT TURN POSITIONING GUIDE REFLECTORS WITH 4" YELLOW LINES</p>	<p>General note: 1) Surface mount Raised Pavement Markers (RPMs) unless otherwise specified.</p> <p>LEGEND</p> <p>← Direction Of Travel, Increasing Stationing or Thru Traffic Side</p> <p>— Lane line dimensions are shown on the striping plans</p> <p>□ Mono-directional crystal white marker reflects white to the left in this symbol</p> <p>▣ Bi-directional yellow marker reflects yellow both left and right in this symbol</p>		

CALC. BOOK NO. _N/A_	SDR DATE _01/03/2022_
NOTE: All material and workmanship shall be in accordance with the current Oregon Standard Specifications.	
OREGON STANDARD DRAWINGS	
PAVEMENT MARKING STANDARD DETAIL BLOCKS	
2021	
DATE	REVISION DESCRIPTION
07/2020	Changed min. width of TM B from 6' to 4.5'
01/2022	Removed 'LANE' from W-2/R-20R title

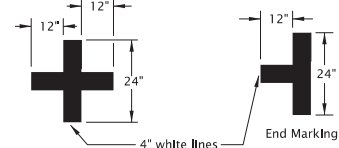
 <p>CW</p> <p>STANDARD CROSSWALK TWO 1' WHITE BARS</p> <p>Install per Standard Drawing TM530</p>	 <p>CW-SC</p> <p>3" min. to 5" max. (adjust spacing to miss wheel tracks)</p> <p>STAGGERED CONTINENTAL CROSSWALK 2' WHITE BARS</p> <p>Install per Standard Drawing TM530</p>	 <p>S</p> <p>STOP BAR 1' WHITE BAR</p> <p>Install per Standard Drawing TM530</p>	 <p>S-2</p> <p>STOP BAR - LARGE 2' WHITE BAR</p> <p>Install per Standard Drawing TM530</p>	 <p>S-RM</p> <p>Extend to EP if $X < 20'$</p> <p>RAMP METER STOP BAR 1' & 8" WHITE BARS</p> <p>For multi-lane ramp meter applications</p>								
 <p>BR</p> <p>BIKE RIGHT TURN STENCIL (white)</p> <p>Center marking within lane width For proportion details, see current version of Standard Highway Signs</p>	 <p>BS</p> <p>BIKE LANE STANDARD STENCIL (white)</p> <p>Center marking within lane width For proportion details, see current version of Standard Highway Signs</p>	 <p>BL</p> <p>BIKE LEFT TURN STENCIL (white)</p> <p>Center marking within lane width For proportion details, see current version of Standard Highway Signs</p>	 <p>BRS</p> <p>BIKE RIGHT TURN STRAIGHT STENCIL (white)</p> <p>Center marking within lane width For proportion details, see current version of Standard Highway Signs</p>	 <p>BLS</p> <p>BIKE LEFT TURN STRAIGHT STENCIL (white)</p> <p>Center marking within lane width For proportion details, see current version of Standard Highway Signs</p>								
 <p>SLM</p> <p>SHARED LANE MARKING (white)</p> <p>Center marking within lane width or as shown For proportion details, see current version of Standard Highway Signs</p>	 <p>B</p> <p>BIKE STENCIL (white)</p> <p>Used for Intersection Bicycle Box applications Place marking within bicycle box, centered with motor vehicle lane width</p>	 <p>BD</p> <p>BICYCLE DETECTOR MARKING (white)</p> <p>Place Bicycle Detector Pavement Marking in optimum location where bicycle acuates the traffic signal</p>	 <p>GRN</p> <p>GREEN SUPPLEMENTAL BICYCLE LANE SOLID LINE (green)</p>	 <p>BLE-G</p> <p>GREEN SUPPLEMENTAL BICYCLE LANE DOTTED LINE EXTENSION (green)</p>								
 <p>BUS</p> <p>BUS (white)</p> <p>Center marking within lane width For letter proportion details, see current version of Standard Highway Signs</p>	 <p>ONLY</p> <p>ONLY (white)</p> <p>Center marking within lane width For letter proportion details, see current version of Standard Highway Signs</p>	 <p>SCHOOL</p> <p>SCHOOL (white)</p> <p>Center marking within lane width For letter proportion details, see current version of Standard Highway Signs</p>	 <p>SCHOOL - LARGE</p> <p>SCHOOL - LARGE (white)</p> <p>Center marking within width of two lanes For letter proportion details, see current version of Standard Highway Signs</p>	 <p>CROSSING</p> <p>CROSSING - LARGE (white)</p> <p>Center marking within width of two lanes For letter proportion details, see current version of Standard Highway Signs</p>								
 <p>X-ING</p> <p>X-ING (white)</p> <p>Center marking within lane width For letter proportion details, see current version of Standard Highway Signs</p>	 <p>P</p> <p>ON-STREET PARKING DETAIL (white)</p> <p>4" white lines End Marking</p>	<p>General Note:</p> <p>1. Arrow, letter, and bike symbol dimensions nominal.</p>										
<p>LEGEND</p> <p>← Direction of Travel</p>			<p>CALC. BOOK NO. ___N/A___</p> <p><i>The selection and use of this Standard Drawing, while designed in accordance with generally accepted engineering principles and practices, is the sole responsibility of the user and should not be used without consulting a Registered Professional Engineer.</i></p>	<p>SDR DATE: ___01/03/2020___</p> <p>NOTE: All material and workmanship shall be in accordance with the current Oregon Standard Specifications.</p> <p>OREGON STANDARD DRAWINGS</p> <p>PAVEMENT MARKING STANDARD DETAIL BLOCKS</p> <p>2021</p> <table border="1"> <thead> <tr> <th>DATE</th> <th>REVISION DESCRIPTION</th> </tr> </thead> <tbody> <tr> <td> </td> <td> </td> </tr> <tr> <td> </td> <td> </td> </tr> <tr> <td> </td> <td> </td> </tr> </tbody> </table>	DATE	REVISION DESCRIPTION						
DATE	REVISION DESCRIPTION											

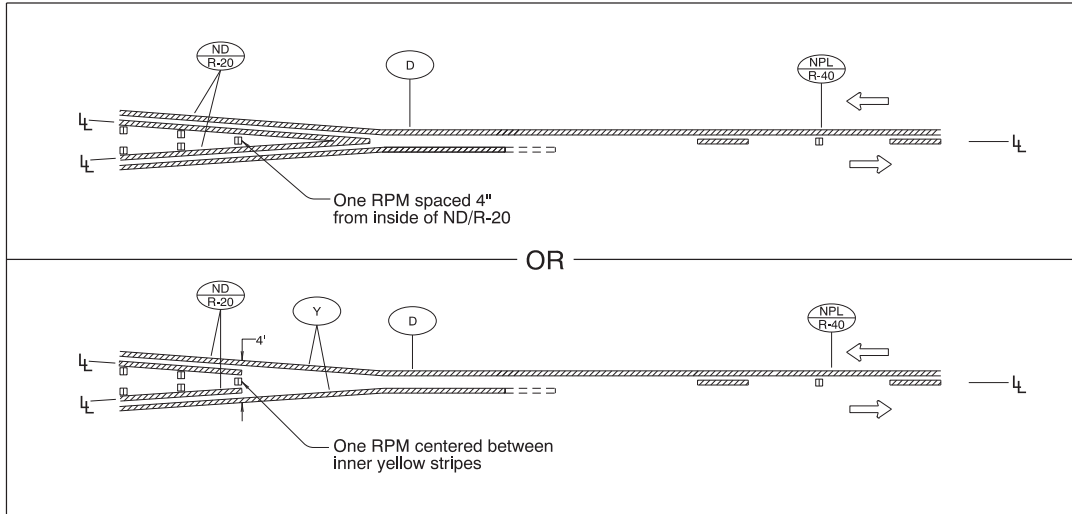

MEDIAN WIDTH TRANSITION

(TWO NARROW DOUBLE YELLOW LINES TO ONE-DIRECTION NO-PASSING LINE)
(Refer to TM539 for additional details)

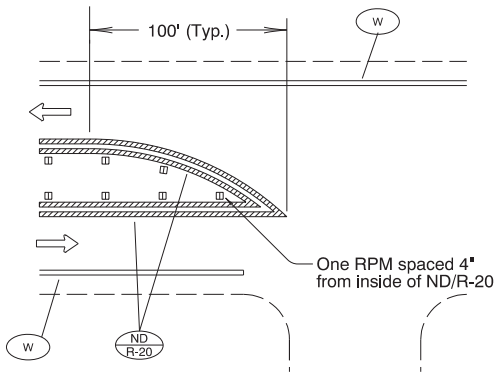

MEDIAN BULLNOSE DETAIL

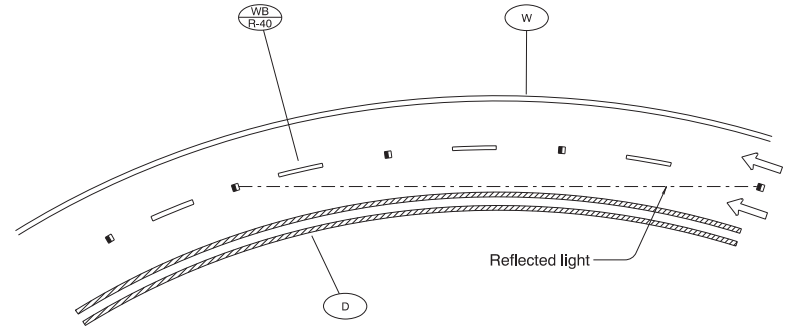

NOTE:
On one way sections the marker shall be installed with the reflective surface aimed to direct the reflected light back three markers.

(a) PAVEMENT MARKER INSTALLATION FOR MONO-DIRECTIONAL RAISED PAVEMENT MARKERS

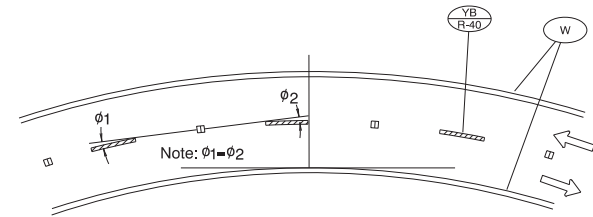

(b) PAVEMENT MARKER INSTALLATION FOR BI-DIRECTIONAL RAISED PAVEMENT MARKERS

PAVEMENT MARKER INSTALLATION ON HORIZONTAL CURVES

LEGEND

- Mono-Directional White (marker reflects white to left in this symbol)
- Bi-Directional Yellow (marker reflects yellow to both the left and right in this symbol)
- Increasing stationing from left to right
- ← Direction of Travel
- ⊥ Lane line dimensions are shown on the striping plans.

To be accompanied by Standard Dwg. Nos. TM500 thru TM504

CALC. BOOK NO. <u> N/A </u>	SDR DATE <u> July 1, 2015 </u>
NOTE: All material and workmanship shall be in accordance with the current Oregon Standard Specifications	
OREGON STANDARD DRAWINGS	
PAVEMENT MARKERS	
2021	
DATE	REVISION DESCRIPTION

The selection and use of this Standard Drawing, while designed in accordance with generally accepted engineering principles and practices, is the sole responsibility of the user and should not be used without consulting a Registered Professional Engineer.

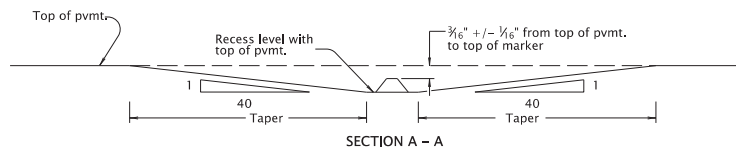
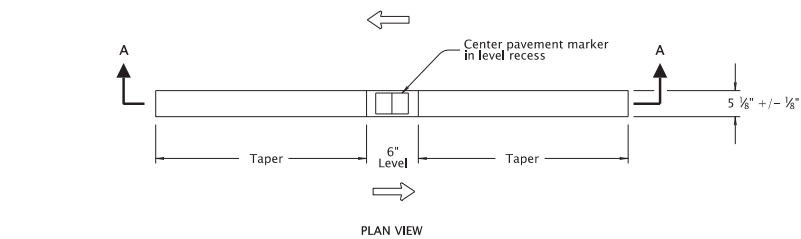

BI-DIRECTIONAL RECESSED PAVEMENT MARKER DETAIL

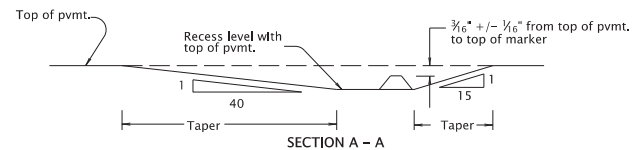
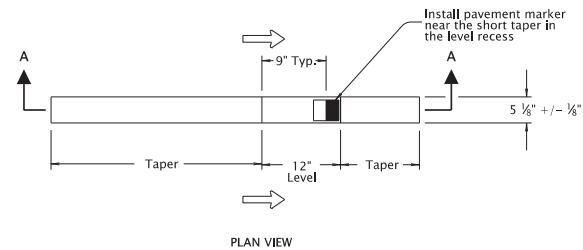

MONO-DIRECTIONAL RECESSED PAVEMENT MARKER DETAIL

TM517

LEGEND

- ← Direction of Travel
- ▢ Bi-directional yellow marker reflects yellow both left and right in this symbol
- Mono-directional crystal white marker reflects white to the left in this symbol

To be accompanied by Standard Dwg. Nos. TM502 and TM515

CALC. BOOK NO. -- N/A --		SDR DATE -- 02/06/2021 --	
NOTE: All material and workmanship shall be in accordance with the current Oregon Standard Specifications.			
OREGON STANDARD DRAWINGS			
RECESSED PAVEMENT MARKERS			
2021			
DATE	REVISION DESCRIPTION		
07/2021	Updated to better fit ODOT drafting standards		

The selection and use of this Standard Drawing, while designed in accordance with generally accepted engineering principles and practices, is the sole responsibility of the user and should not be used without consulting a Registered Professional Engineer.

Effective Date: June 01, 2022 - November 30, 2022

TM517

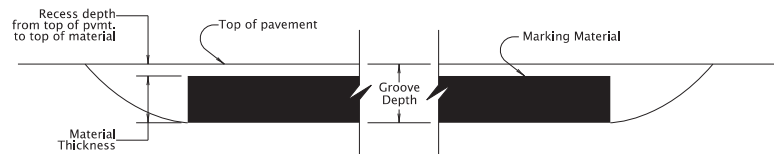
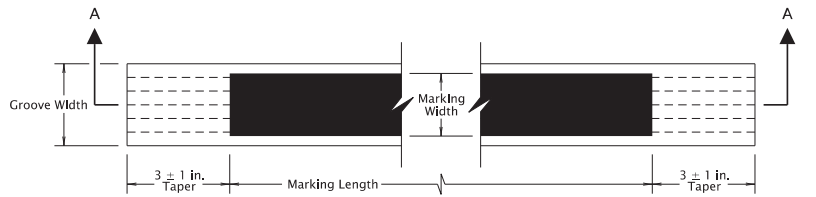

SECTION A - A

GROOVE INSTALLED GROOVE AND MATERIAL DIMENSIONS

Pavement Marking Material Type	Groove Depth	Recess Depth	Material Thickness
Durable Method 'A' & Method 'D'	220 ± 20 mlls	45 ± 5 mlls	Var.
High Performance	60 ± 10 mlls	Var.	25 mlls

GROOVE INSTALLED GROOVE WIDTH

Pavement Marking Width	Groove Width
4 In. Markings	7 ± 0.125 In.
Non 4 In. Markings	Marking width + 1 ± 0.125 In.

GROOVE INSTALLED MARKINGS

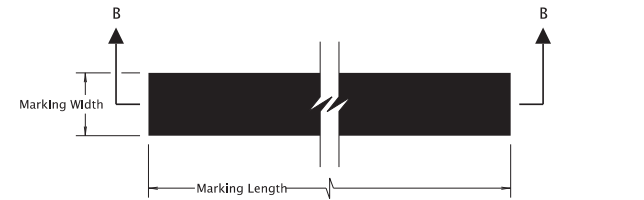

SECTION B - B

SURFACE INSTALLED MATERIAL THICKNESS

Pavement Marking Material Type	Thickness
Durable Method 'A' & Method 'B' & Method 'D'	120 mlls
High Performance	25 mlls

SURFACE INSTALLED MARKINGS

General Notes:

- 1) See Standard Drawing TM500 and/or project plans for marking length and width dimensions.
- 2) See Standard Specification 00850.46 for marking installation tolerances.

CALC. BOOK NO. _ _ N/A _ _ _ _ _

SDR DATE _ _ 02/06/2021 _ _ _ _ _

NOTE: All material and workmanship shall be in accordance with the current Oregon Standard Specifications.

OREGON STANDARD DRAWINGS
DURABLE & HIGH PERFORMANCE
PAVEMENT MARKINGS
SURFACE & GROOVE INSTALLED
NON-PROFILED

2021

DATE	REVISION DESCRIPTION
07/2021	Changed groove width for 4 in. markings

The selection and use of this Standard Drawing, while designed in accordance with generally accepted engineering principles and practices, is the sole responsibility of the user and should not be used without consulting a Registered Professional Engineer.

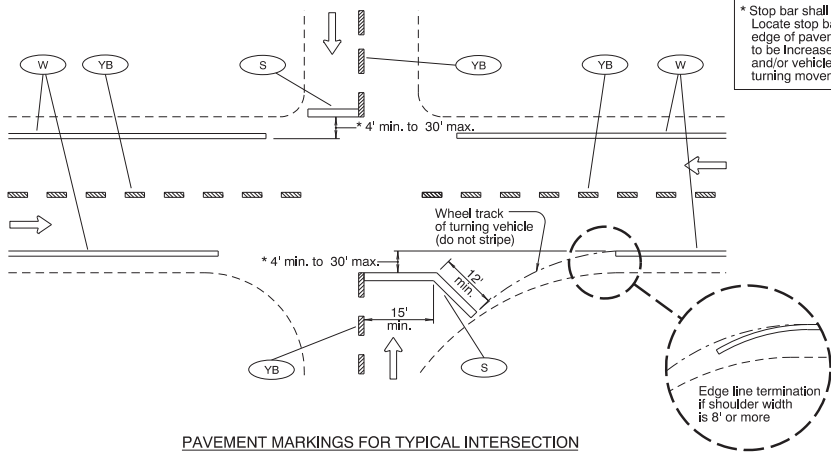

PAVEMENT MARKINGS FOR TYPICAL INTERSECTION

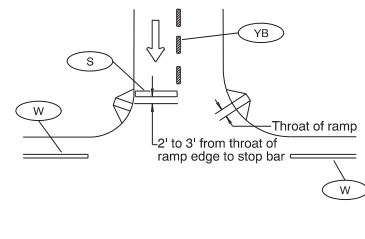

Detail "A"
STOP BAR PLACEMENT WITH
RESPECT TO PEDESTRIAN RAMP

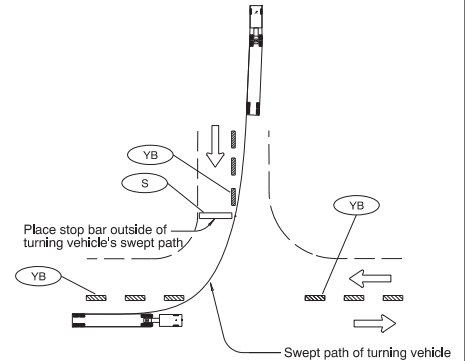

Detail "B"
STOP BAR PLACEMENT WITH
RESPECT TO TURN RADI

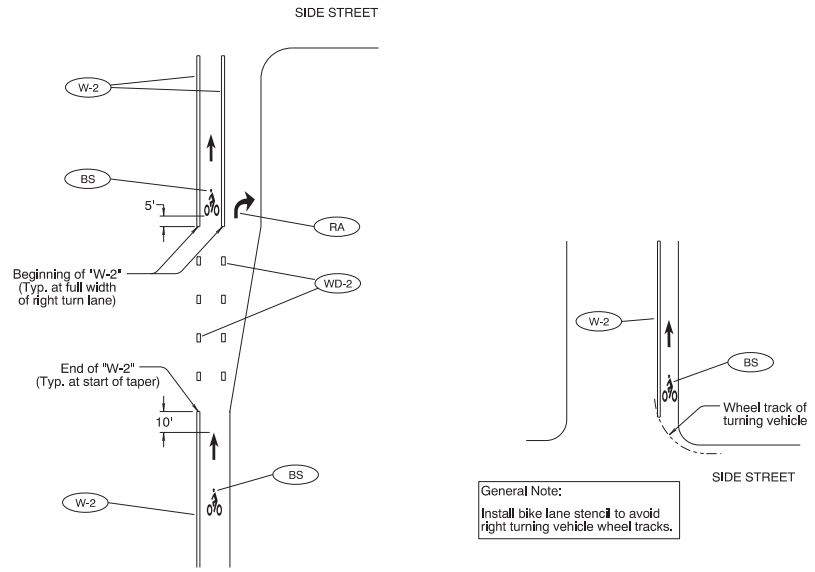

INSTALLATION OF BIKE LANE STENCILS
FOR BIKE LANE SEPARATED BY RIGHT TURN LANE

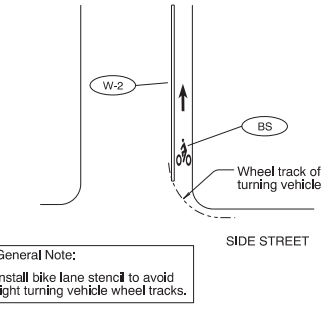

INSTALLATION OF BIKE LANE STENCILS
FOLLOWING INTERSECTIONS

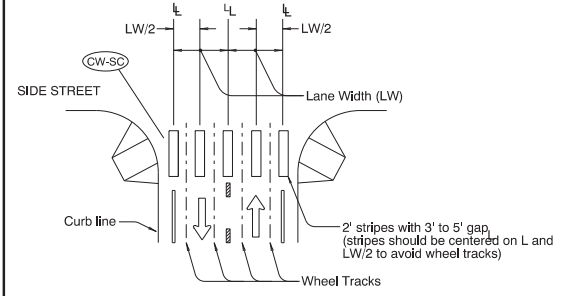

STAGGERED CONTINENTAL LAYOUT

General Note:
1. Install crosswalk bars such that the throat of the ADA ramp is entirely within crosswalk markings, or 5' back of extended fog line, edge of pavement, or curb face.

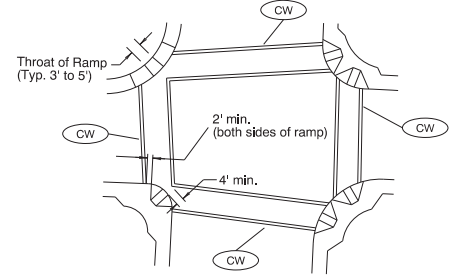

STANDARD CROSSWALK BARS
AT INTERSECTION

To be accompanied by Standard Dwg. Nos. TM500 thru TM504

CALC. BOOK NO. <u> N/A </u>	SDR DATE <u> July 10, 2020 </u>
NOTE: All material and workmanship shall be in accordance with the current Oregon Standard Specifications	
OREGON STANDARD DRAWINGS	
INTERSECTION PAVEMENT MARKINGS (CROSSWALK, STOP BAR & BIKE LANE STENCIL)	
2021	
DATE	REVISION DESCRIPTION

The selection and use of this Standard Drawing, while designed in accordance with generally accepted engineering principles and practices, is the sole responsibility of the user and should not be used without consulting a Registered Professional Engineer.

LEGEND
 Direction of Travel
 L - Lane line dimensions are shown on the striping plans

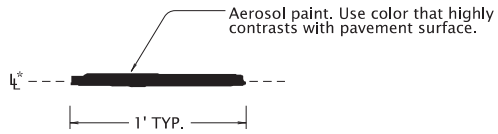

CONTROL POINT

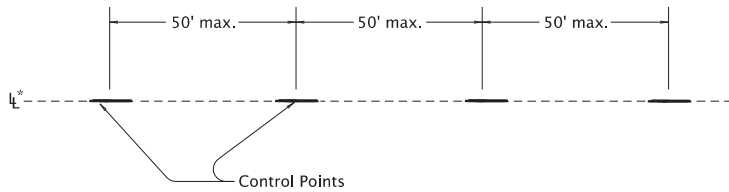

CONTROL POINT LAYOUT - TANGENT SECTIONS

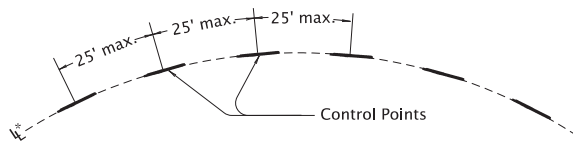

CONTROL POINT LAYOUT - CURVE SECTIONS

General note:

1.) Use control points to make continuous narrow guideline as specified.

* Control points are placed along the lane line for all longitudinal lines except the following:



For center lines only

A control point layout 4" offset from the lane line is required for a ND line when used as a center line.

TM560

LEGEND

ℓ — Lane line dimensions are shown on the striping plans.

To be accompanied by Standard Dwg. Nos. TM500 thru TM504

CALC. BOOK NO. — N/A —		SDR DATE — 02/01/2020 —	
NOTE: All material and workmanship shall be in accordance with the current Oregon Standard Specifications.			
OREGON STANDARD DRAWINGS			
ALIGNMENT LAYOUT: GENERAL			
2021			
DATE	REVISION DESCRIPTION		
07/2020	Extended accompanied by drawings to include TM504		

The selection and use of this Standard Drawing, while designed in accordance with generally accepted engineering principles and practices, is the sole responsibility of the user and should not be used without consulting a Registered Professional Engineer.

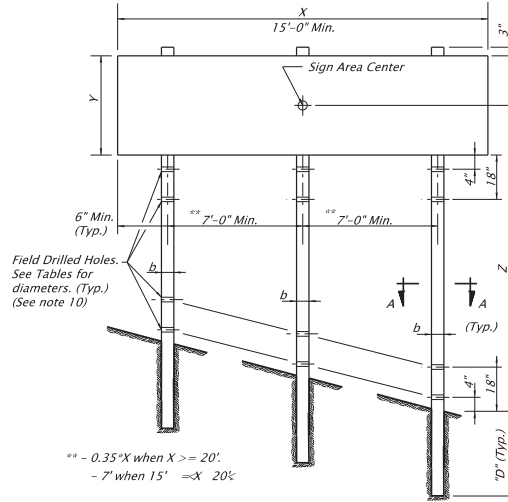
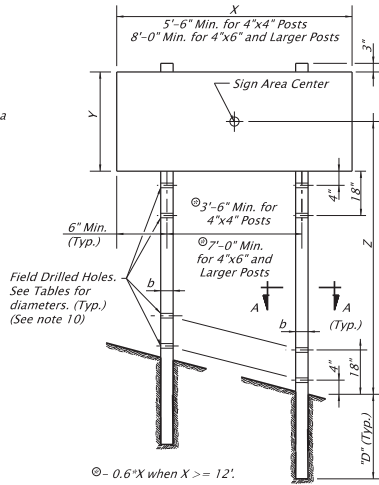
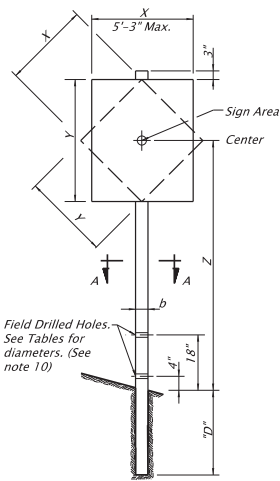

ELEVATION
No scale

		$(X * Y * Z)$ in ft^3 - Maximum												Field Drilled Hole Diameters	Post Embedment Depth "D"
		3 Second Gust Wind Speed (TM671)													
		85 MPH				95 MPH				105 and 110 MPH					
		Number of Posts				Number of Posts				Number of Posts					
POST SIZE $b \times d$		1	2	3*	3*	1	2	3*	3*	1	2	3*	3*	Not Req'd	
		X=15'		X≥20'		X=15'		X≥20'		X=15'		X≥20'			
4" x 4"		77	154	165	231	62	124	132	186	56	112	120	168		4' - 0"
4" x 6"		162	324	347	486	130	260	278	390	117	234	250	351	1 1/2"	5' - 0"
6" x 6"		270	540	578	810	216	432	462	648	195	390	417	585	2"	5' - 0"
6" x 8"		494	988	1058	1482	395	790	846	1185	356	712	762	1068	3"	7' - 0"

PERMANENT WOOD POST TABLE

** - Linear Interpolate X*Y*Z 3 post values for signs greater than 15' and less than 20'.
** - See note 8

		$(X * Y * Z)$ in ft^3 - Maximum												Field Drilled Hole Diameters	Post Embedment Depth "D"
		3 Second Gust Wind Speed (TM671)													
		85 MPH				95 MPH				105 and 110 MPH					
		Number of Posts				Number of Posts				Number of Posts					
POST SIZE $b \times d$		1	2	3*	3*	1	2	3*	3*	1	2	3*	3*	Not Req'd	
		X=15'		X≥20'		X=15'		X≥20'		X=15'		X≥20'			
4" x 4"		122	244	261	366	98	196	210	294	88	176	188	264		4' - 0"
4" x 6"		257	514	550	771	205	410	439	615	185	370	396	555	1 1/2"	5' - 0"
6" x 6"		426	852	912	1278	341	682	730	1023	308	616	660	924	2"	5' - 0"
6" x 8"		779	1558	1669	2337	624	1248	1337	1872	563	1126	1206	1689	3"	7' - 0"

TEMPORARY WOOD POST TABLE

** - Linear Interpolate X*Y*Z 3 post values for signs greater than 15' and less than 20'.
** - See note 9

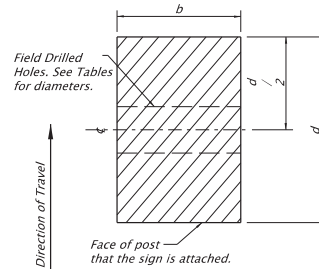

SECTION A-A
No scale

General Notes:

1. Wood posts are available in the following commercial lengths: 12', 14', 16', 18', 20', 22', 24', 26'.
2. Material shall be Douglas Fir No. 1 and according to Section 02110.40.
3. For horizontal and vertical clearances of permanent signs refer to TM200 and of temporary signs refer to TM822.
4. Wood post design in accordance with the 5th Edition 2009 AASHTO Standard Specifications for Structural Supports for Highway Signs, Luminaires, and Traffic Signals.
5. Use the 3 second gust wind speeds shown on TM671 for the site specific sign location.
6. General design parameters are $K_z = 0.87$, SIF (duration factor) = 1.6, C_d (sign) = 1.20, and $G = 1.14$.
7. The sign width to sign height or sign height to sign width ratio shall not exceed 5.0.
8. Permanent signing uses an $I_r = 0.71$ for a recurrence interval of 10 years.
9. Temporary signing uses an $I_r = 0.45$ for a recurrence interval of 1.5 years.
10. Posts protected by barrier or guardrail do not require field drilled holes.
11. 4" x 4" posts should not be used in snow plow areas.

Post Embedment Installation:

1. Excavate the hole at least 12" larger in diameter than the diagonal dimension of the post. Maintain at least 6" of space around the edges of the post to accommodate compaction equipment.
2. Align the post in the hole to a vertical position.
3. The space around the wood post shall be backfilled to finished ground surface.
4. Backfill with selected general backfill meeting the requirements of 00330.13.
5. Place in layers not greater than 6 inches.
6. Solidly ram and tamp the layers into the excavation area around the post.
7. Dampen during placement if too dry to compact properly.
8. Replace and finish the surface around the post to match the surrounding surface.

Accompanied by dwgs. TM200, TM671, TM822

CALC. BOOK NO. 5850	SDR DATE 07-JAN-2022
NOTE: All material and workmanship shall be in accordance with the current Oregon Standard Specifications	
OREGON STANDARD DRAWINGS	
WOOD POST SIGN SUPPORTS	
2021	
DATE	REVISION DESCRIPTION
01/22	Added 3'-6" Min. spacing for 4"x4" posts and 8'-0" Min. sign widths for 4"x6" and larger posts.

The selection and use of this Standard Drawing, while designed in accordance with generally accepted engineering principles and practices, is the sole responsibility of the user and should not be used without consulting a Registered Professional Engineer.

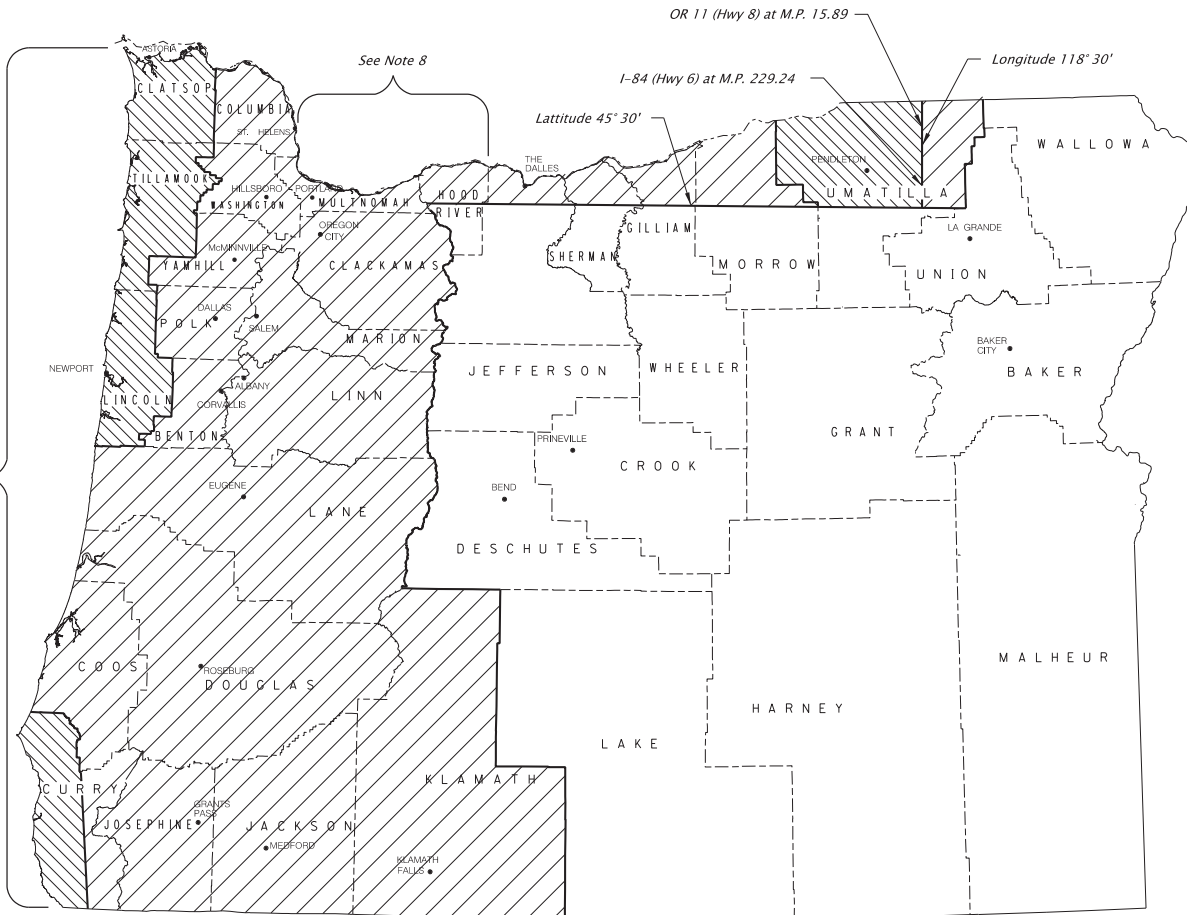

See Note 7

See Note 8

NOTES:

1. The wind velocity map as shown is adapted from AASHTO 2001 4th Edition - "Standard Specifications for Structural Supports for Highway Signs, Luminaires and Traffic Signals", Appendix C, Figure C-3 and Section 3, Figure 3-2. It uses the wind speed map shown in Figure 1609 of the 2007 Oregon Structural Code to account for locations in the State with special wind regions.
2. The wind velocities shown above are 3-Second Gust wind velocities.
3. The Exposure Category is C.
4. The mean recurrence interval is 50-Years.
5. Mountainous terrain, gorges, and ocean promontories are classified as special wind regions and shall be examined for unusual wind conditions.
6. The Interval Height (Kz) is 30 ft.
7. All areas with full exposure to ocean winds shall be designated 110 mph areas.
8. Areas in Multnomah and Hood River counties with full exposure to Columbia River Gorge winds shall be designated 110 mph areas.
9. Localities may have adopted wind speed higher than that shown on this map. Those higher wind speed shall be used.



CALC. BOOK NO. _____	SDR DATE 06-JAN-2012
NOTE: All material and workmanship shall be in accordance with the current Oregon Standard Specifications	
OREGON STANDARD DRAWINGS	
3 SECOND GUST WIND SPEED MAP	
2021	
DATE	REVISION DESCRIPTION

The selection and use of this Standard Drawing, while designed in accordance with generally accepted engineering principles and practices, is the sole responsibility of the user and should not be used without consulting a Registered Professional Engineer.

tm800.dgn 04-JAN-2022

TAPER TYPES & FORMULAS	
TAPER	FORMULA
Merging (Lane Closure)	"L"
Shifting	"L"/2 or 1/2"L"
Shoulder Closure	"L"/3 or 1/3"L"
Flagging (See Drg. TM850)	50' - 100'
Downstream (Termination)	Varies (See Drawings)

★ Use Pre-Construction Posted Speed to select the Speed from the Tables below:

TEMPORARY BARRIER FLARE RATE TABLE	
★ SPEED (mph)	MINIMUM FLARE RATE
≤ 30	8:1
35	9:1
40	10:1
45	12:1
50	14:1
55	16:1
60	18:1
65	19:1
70	20:1

MINIMUM LENGTHS TABLE					
"L" VALUE FOR TAPERS (ft)					BUFFER "B" (ft)
★ SPEED (mph)	W = Lane or Shoulder Width being closed or shifted				
	W ≤ 10	W = 12	W = 14	W = 16	
25	105	125	145	165	75
30	150	180	210	240	100
35	205	245	285	325	125
40	265	320	375	430	150
45	450	540	630	720	180
50	500	600	700	800	210
55	550	660	770	880	250
60	600	720	840	960	285
65	650	780	910	1000	325
70	700	840	980	1000	365
FREEWAYS					
55	1000	1000	1000	1000	250
60	1000	1000	1000	1000	285
65	1000	1000	1000	1000	325
70	1000	1000	1000	1000	365

NOTES:

- For Lane closures where W < 10', use "L" value for W = 10'.
- For Shoulder closures where W < 10', use "L" value for W = 10' or calculate "L" using formula, for Speeds ≥ 45: L = WS, Speeds < 45: L = S²W/60, S = Speed, W=Width

TRAFFIC CONTROL DEVICES (TCD) SPACING TABLE				
★ SPEED (mph)	Sign Spacing (ft)			Max. Channelizing Device Spacing (ft)
	A	B	C	
20 - 30	100	100	100	20
35 - 40	350	350	350	20
45 - 55	500	500	500	40
60 - 70	700	700	700	40
Freeway	1000	1500	2640	40

NOTES:

- Place traffic control devices on 10 ft. spacing for intersection and access radii.
- When necessary, sign spacing may be adjusted to fit site conditions.
- Limit spacing adjustments to 30% of the "A" dimension for all speeds.

NOTES:

- When paved shoulders adjacent to excavations are less than four feet wide protect longitudinal abrupt edge as shown.
- Use aggregate wedge when abrupt edge is 2 inches or greater.

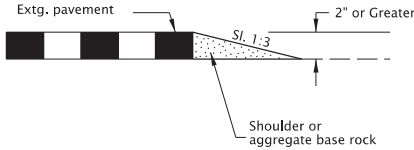

EXCAVATION ABRUPT EDGE

NOTES:

- Abrupt edges may be created by paving, operations, excavations or other roadway work. Use abrupt edge signing for longitudinal abrupt edges of 1 inch or greater.
- If the excavation is located on left side of traffic, replace the 8' B(III)R barricades with 8' B(III)L barricades and replace the "RIGHT" (CW21-8C) riders with "LEFT" (CW21-8A) riders.
- Continue signing and other traffic control devices throughout excavation area at spacings shown.
- If roll-up signs are used, attach the correct (CW21-9) plaques to the sign face using hook and loop fasteners. Place roll-up signs in advance of barricades.

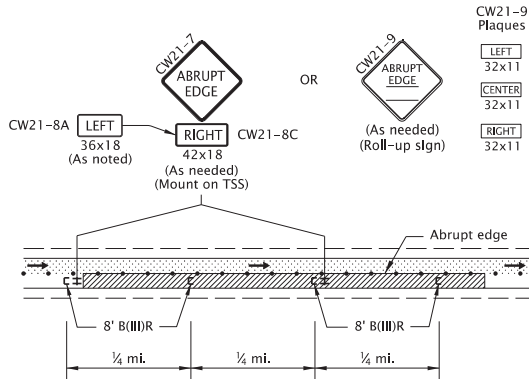

TYPICAL ABRUPT EDGE DELINEATION

NOTES:

- Install PCMS beyond the outside shoulder, when possible.
- Use the appropriate type of barricade panels for PCMS location. Right shoulder, use Type B(III)R. Left shoulder, use Type B(III)L.
- Use six drums in shoulder taper on 20' spacing. The drums and barricade may be omitted when PCMS is placed behind a roadside barrier.
- Detail as shown is used for trailered and non-crashworthy components of:
 - Portable Traffic Signals
 - Smart Work Zone Systems

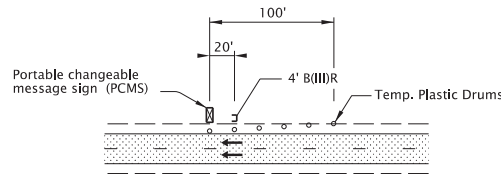

PORTABLE CHANGEABLE MESSAGE SIGN (PCMS) INSTALLATION

NOTES:

- Install Flagger Station Lighting beyond the outside shoulder, where practical.
- Use six tubular markers in shoulder taper on 10' spacing.
- Place cart / generator / power supply off of the shoulder, as far as practical.

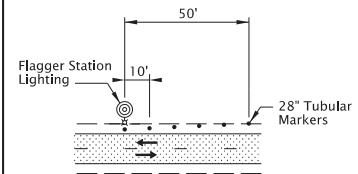

FLAGGER STATION LIGHTING DELINEATION

GENERAL NOTES FOR ALL TCP DRAWINGS:

- Signs and other Traffic Control Devices (TCD) shown are the minimum required.
- Place a barricade approx. 20' ahead of all sequential arrow boards.
- Arrows shown in roadway are directional arrows to indicate traffic movements.
- All signs are 48" x 48" unless otherwise shown. Use fluorescent orange sheeting for the background of all temporary warning signs.
- All diamond shaped warning signs mounted on barrier sign supports shall be 36" by 36". All other signs mounted on barrier sign supports shall not exceed 12 sq. ft. in total sign area.
- Low speed highways have a pre-construction posted speed of 40 mph or less. High speed highways have a pre-construction posted speed of 45 mph or higher.
- Do not locate sign supports in locations designated for bicycle or pedestrian traffic.
- Combine drawing details to complete temporary traffic control for each work activity.
- To be accompanied by Dwg. Nos. TM820 & TM821.

- Temp. Plastic Drums See TCD Spacing Table for max. spacing.
- 28" Tubular Markers See TCD Spacing Table for max. spacing.
- UNDER TRAFFIC
- UNDER CONSTRUCTION

CALC. BOOK NO. _ _ _ _ _ TM09-01 _ _ _	SDR DATE _ _ _ _ _ 04-JAN-2022 _ _ _ _ _
NOTE: All material and workmanship shall be in accordance with the current Oregon Standard Specifications	
OREGON STANDARD DRAWINGS	
TABLES, ABRUPT EDGE AND PCMS DETAILS	
2021	
DATE	REVISION DESCRIPTION

The selection and use of this Standard Drawing, while designed in accordance with generally accepted engineering principles and practices, is the sole responsibility of the user and should not be used without consulting a Registered Professional Engineer.

008MWL

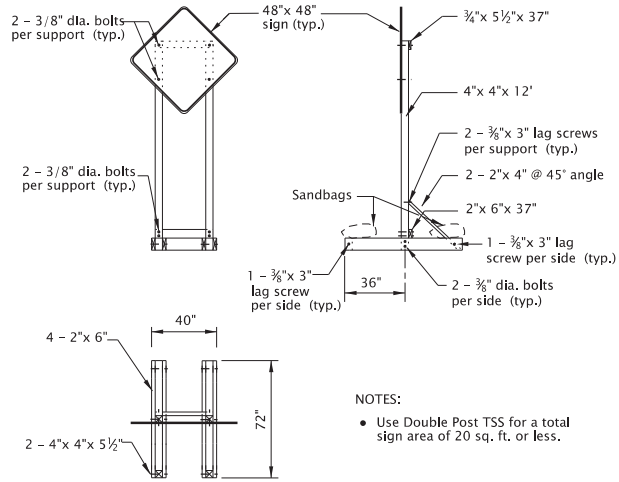

- NOTES:
- Use Double Post TSS for a total sign area of 20 sq. ft. or less.

DOUBLE POST DETAIL

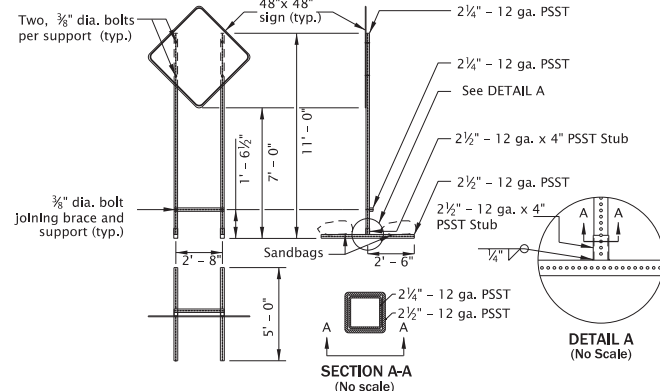

- NOTES:
- Use PSST TSS's for a total sign area of 16 sq. ft. or less.
 - All members shall have a minimum yield stress of 50 ksi.
 - Galvanize steel according to ASTM A653 with coating designation G90. Remove Galvanizing from steel before welding. Repair Galvanizing according to ASTM A780.
 - Use A325 Bolts or equivalent.
 - 2 1/4" - 12 ga. PSST to extend entire length inside of the 2 1/2" - 12 ga. x 4" PSST Stub.
 - Do not use bolt to secure 2 1/4" PSST inside of the 2 1/2" - 12 ga. x 4" PSST Stub.
 - Weld steel according to American Welding Society (AWS) D.1.1.

PERFORATED STEEL SQUARE TUBE (PSST) DETAIL

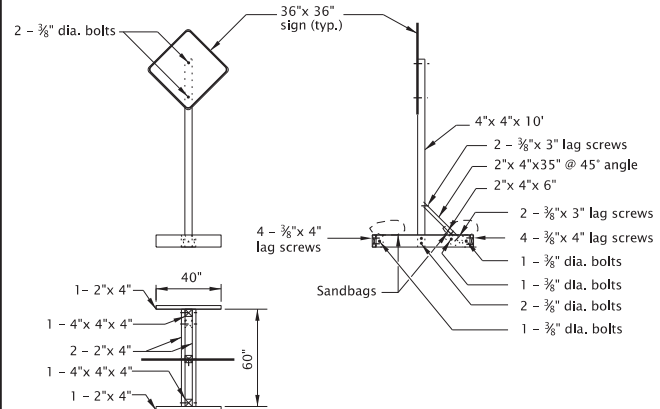

- NOTES:
- Use Single Post TSS for a total sign area of 12 sq. ft. or less.
 - Use Single Post TSS for mounting "Business Access" (CG20-11) signs. Do not mount signs on Type II or III Barricades.

SINGLE POST DETAIL

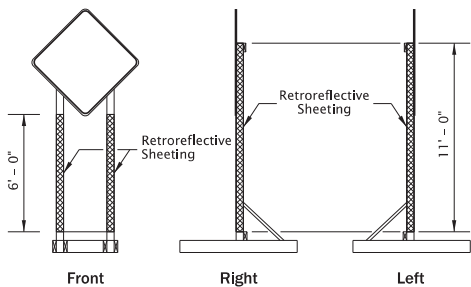

Double Post

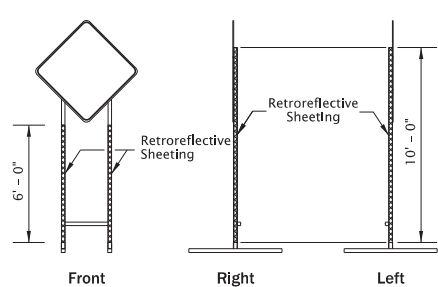

Perforated Steel Square Tube (PSST)

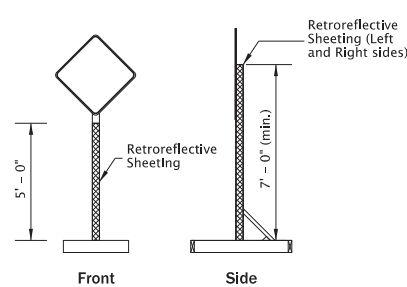

Single Post

Retroreflective Sheeting (Left and Right sides)

TEMPORARY SIGN SUPPORT GENERAL NOTES:

- Do not tip over TSS at any time.
- Do not locate TSS's in locations that block pedestrian or bicycle traffic.
- For wooden TSS's, use either Douglas Fir or Hem Fir, which is surfaced four sides (S4S) and free of heart center (FOHC).
- See "Temporary Sign Placement" detail on TM822 for sign installation heights.
- Do not place or stack ballast more than 24" above the ground.
- When sign is inconsistent with current work zone conditions, cover sign; or turn sign 90 degrees away from approaching traffic. Remove TSS from roadway when signing is not needed for more than 3 days.
- Place a minimum of 50 lbs of sandbags on each of the four TSS supports legs. (25 lb. max per bag) (min. 100 lbs per side of each TSS).
- See Dwg. No. TM204 for flag board mounting detail.

- NOTES:
- Apply fluorescent orange, ANSI Type VIII or IX retroreflective sheeting to TSS posts, as shown, for all temporary signs, except "STOP" and "DO NOT ENTER". For "STOP" and "DO NOT ENTER" signs, used red ANSI Type III or IV retroreflective sheeting on the TSS posts.
 - Apply sign post retroreflectivity to each TSS post facing front; and to the left and right sides of the TSS, as shown. Use 3" wide sheeting for wood post TSS's. Use 2" wide sheeting for PSST TSS's.
 - Sheeting may be applied directly to post material; or applied to a rigid, lightweight substrate, then securely attached to the posts.

SIGN POST REFLECTIVE SHEETING PLACEMENT

CALC. BOOK NO. _____ N/A _____	SDR DATE _____ 01-JUL-2020 _____
NOTE: All material and workmanship shall be in accordance with the current Oregon Standard Specifications	
OREGON STANDARD DRAWINGS	
TEMPORARY SIGN SUPPORTS	
2021	
DATE	REVISION DESCRIPTION

The selection and use of this Standard Drawing, while designed in accordance with generally accepted engineering principles and practices, is the sole responsibility of the user and should not be used without consulting a Registered Professional Engineer.

NOTES:

- Do not block bicycle lanes, sidewalks, or TPAR's with sign supports. Maintain minimum widths for these facilities according TCP Design Manual, MUTCD, ADA, or as directed.
- To be accompanied by Dwg. Nos. TM670, TM671, TM687, TM688 & TM689.

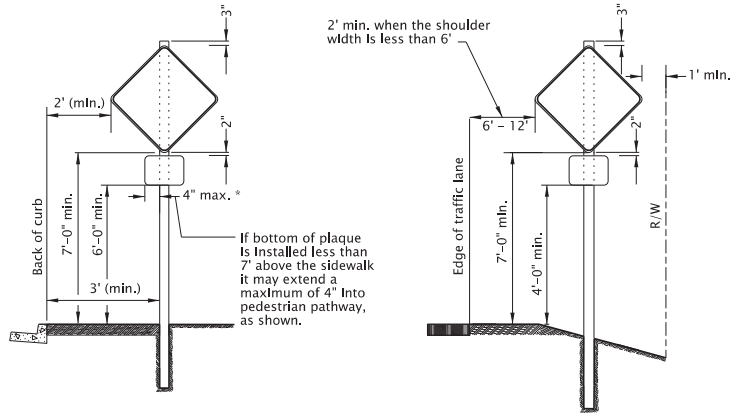

Urban Areas With Curb/Sidewalk

Rural Areas

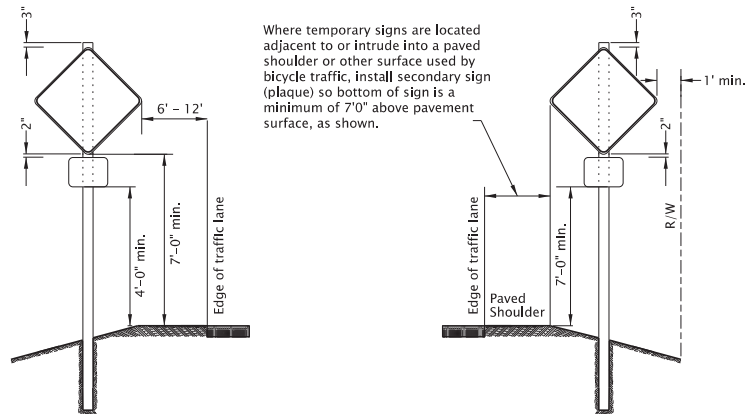

Divided Highway/Freeway Medians
No Curb/Sidewalk

Rural or Urban Areas - Curb or No Curb
Bicycles On Shoulder

TEMPORARY SIGN PLACEMENT

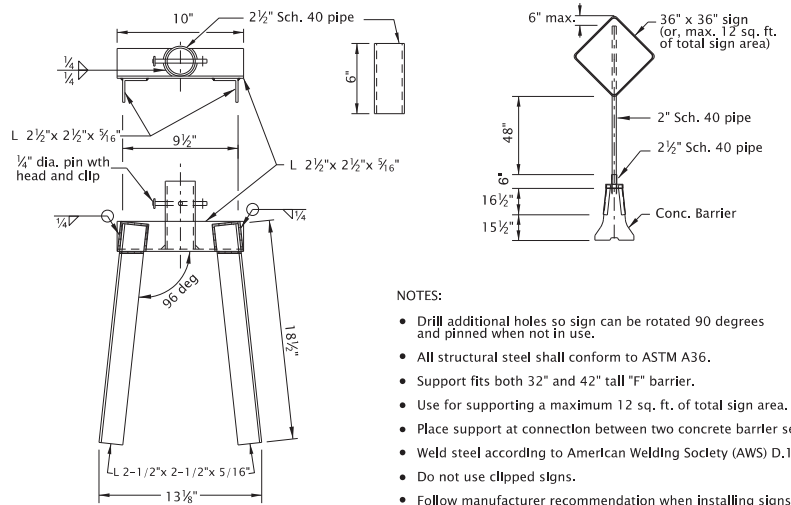

NOTES:

- Drill additional holes so sign can be rotated 90 degrees and pinned when not in use.
- All structural steel shall conform to ASTM A36.
- Support fits both 32" and 42" tall "F" barrier.
- Use for supporting a maximum 12 sq. ft. of total sign area.
- Place support at connection between two concrete barrier sections.
- Weld steel according to American Welding Society (AWS) D.1.1.
- Do not use clipped signs.
- Follow manufacturer recommendation when installing signs on barrier other than concrete.

CONCRETE BARRIER SIGN SUPPORT

CALC. BOOK NO. --- N/A ---	SDR DATE --- 01-JUL-2020 ---
NOTE: All material and workmanship shall be in accordance with the current Oregon Standard Specifications	
OREGON STANDARD DRAWINGS	
TEMPORARY SIGN SUPPORTS	
2021	
DATE	REVISION DESCRIPTION

The selection and use of this Standard Drawing, while designed in accordance with generally accepted engineering principles and practices, is the sole responsibility of the user and should not be used without consulting a Registered Professional Engineer.

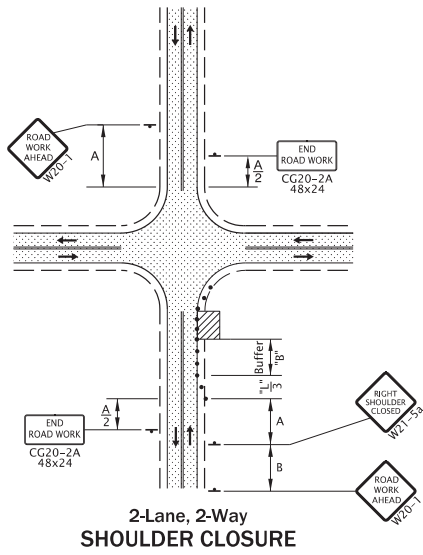

**2-Lane, 2-Way
SHOULDER CLOSURE**

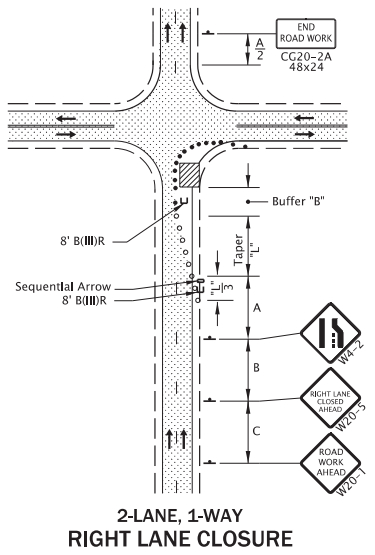

**2-LANE, 1-WAY
RIGHT LANE CLOSURE**

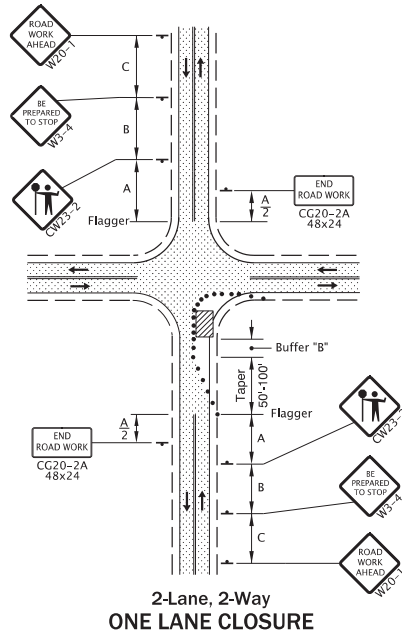

**2-Lane, 2-Way
ONE LANE CLOSURE**

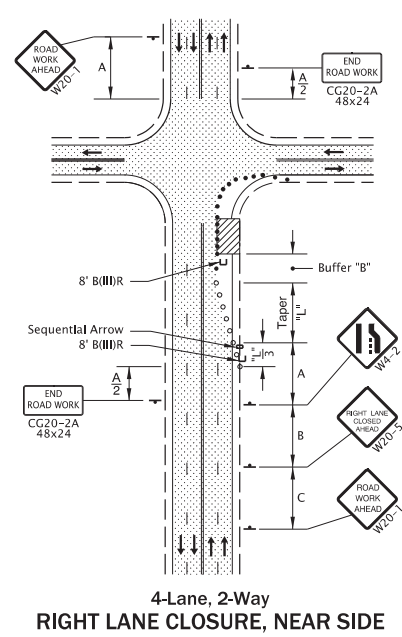

**4-Lane, 2-Way
RIGHT LANE CLOSURE, NEAR SIDE**

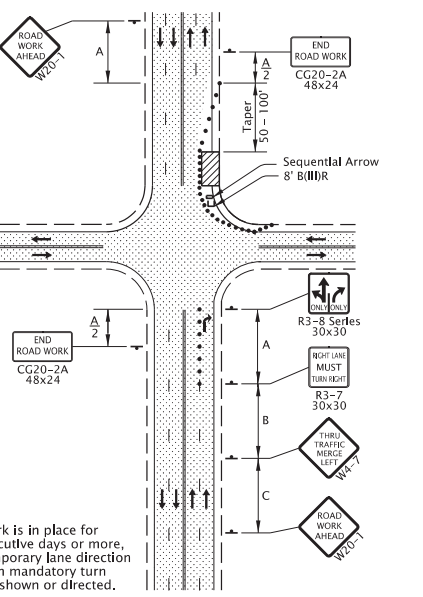

**4-Lane, 2-Way
RIGHT LANE CLOSURE, FAR SIDE**

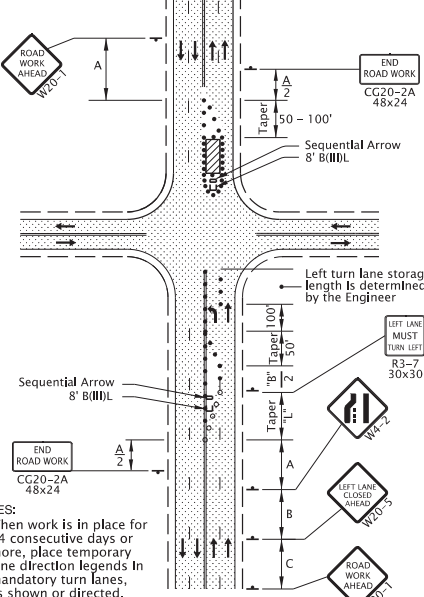

**4-Lane, 2-Way
LEFT LANE CLOSURE, FAR SIDE**

NOTES:
 • When work is in place for 14 consecutive days or more, place temporary lane direction legends in mandatory turn lanes, as shown or directed.

NOTES:
 • When work is in place for 14 consecutive days or more, place temporary lane direction legends in mandatory turn lanes, as shown or directed.

GENERAL NOTES FOR ALL DETAILS:

- Additional Traffic Control Measures (TCM) may be required for all legs of the intersection.
- The "FLAGGER" (CW23-2) symbol sign shall be used only in conjunction with the "BE PREPARED TO STOP" (W3-4) sign.
- To determine Taper Length ("L") and Buffer Length ("B"), use the "MINIMUM LENGTHS TABLE" on Dwg. TM800.
- For left lane or shoulder work, place TCD to close left lane or shoulder. Use "LEFT LANE CLOSED AHEAD" (W20-5) sign, "LEFT LANE ENDS" (W4-2L) symbol sign, or "LEFT SHOULDER CLOSED" (W21-5a) sign, where applicable.
- To determine sign spacing A, B, and C, use "TRAFFIC CONTROL DEVICES (TCD) SPACING TABLE" on Dwg. TM800.
- When a through road intersects within the work zone, place a "ROAD WORK AHEAD" (W20-1) sign in advance of the intersection at sign spacing A.
- Tubular markers may be used in lane closure tapers where posted speed is 40 mph or less.
- Where shoulder width is limited, Sequential Arrow may be placed within the lane closure taper.
- Place channelizing devices around intersection radii, business accesses and driveways at 10' spacing.
- Install a "BICYCLES ON ROADWAY" (CW11-1) sign in advance of the closure when a bike lane is closed, or when the shoulder is closed and bikes are expected.

- To be accompanied by Dwg. Nos. TM820, TM821 & TM840.
- • • • • 28" Tubular Markers
See TCD Spacing Table on TM800 for max. spacing.
- • • • • Temp. Plastic Drums
See TCD Spacing Table on TM800 for max. spacing.

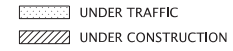

CALC. BOOK NO. _____ N/A _____	SDR DATE _____ 01-JUL-2020 _____
NOTE: All material and workmanship shall be in accordance with the current Oregon Standard Specifications	
OREGON STANDARD DRAWINGS	
INTERSECTION WORK ZONE DETAILS	
2021	
DATE	REVISION DESCRIPTION

The selection and use of this Standard Drawing, while designed in accordance with generally accepted engineering principles and practices, is the sole responsibility of the user and should not be used without consulting a Registered Professional Engineer.

01-JUL-2020

- NOTE:
- Continue "LOOSE GRAVEL" (CW8-7a) and "DO NOT PASS" (R4-1) signing throughout the area at spacing shown.
 - Use advisory speed "XX", 15 mph less than the pre-construction posted speed, or as directed. "XX MPH" placard shall not exceed a posted speed of 35 mph.

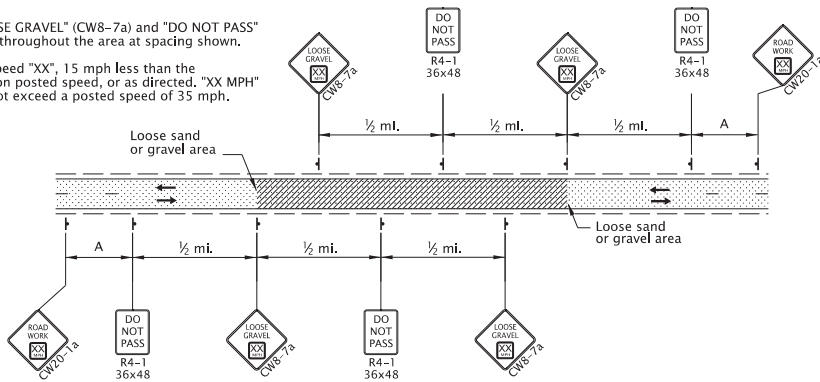

2-Lane, 2-Way Roadway
LOOSE GRAVEL IN ROADWAY SIGNING

- NOTE:
- Continue "ABRUPT EDGE" (CW21-(7,9)) and "DO NOT PASS" (R4-1) signing throughout the area at spacing shown.

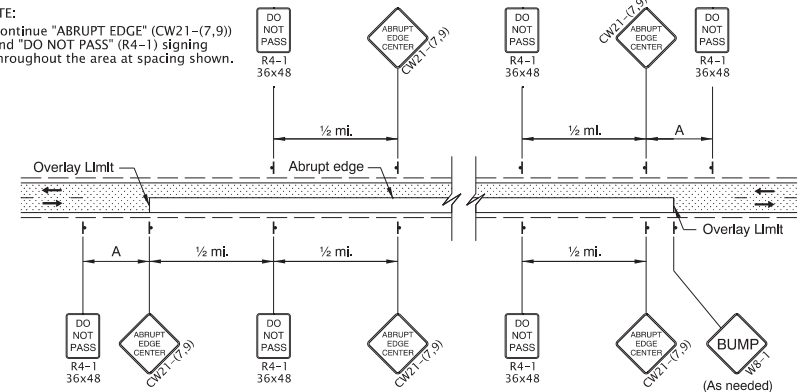

2-Lane, 2-Way Roadway
OVERLAY AREA SIGNING

tm850.dgn

- NOTES:
- Place Advance Flagger and additional signing when traffic queues extend beyond initial warning signing OR when sight distance is restricted.
 - Place additional Tubular Markers for Flagger and Advance Flagger Stations according to FLAGGER STATION DELINEATION detail.
 - Relocate initial "ROAD WORK AHEAD" (W20-1) sign in advance of additional "BE PREPARED TO STOP" (W3-4) and Flagger Ahead (CW23-2) signs, as shown.

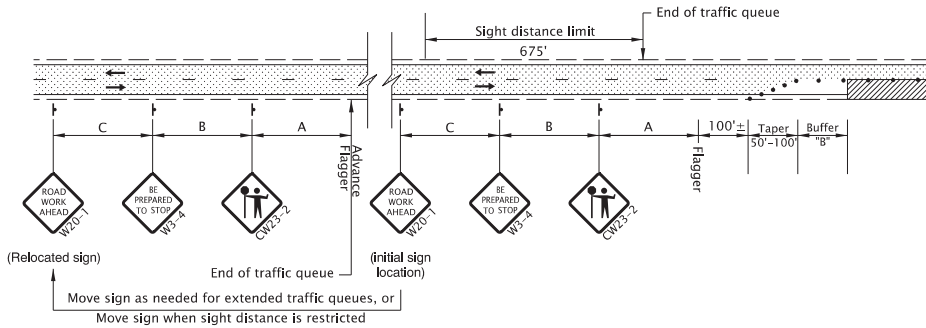

ADVANCE FLAGGER FOR EXTENDED TRAFFIC QUEUES

- NOTE:
- When using pilot cars with flaggers to control traffic during paving operations, the Tubular Marker spacing along centerline may be increased to 200' within the Activity Area, as shown or as directed.
 - Include "WAIT FOR FLAGGER" (CR4-23) signs mounted on Type II Barricade located approx. 50' before each Flagger.
 - Coordinate and control pedestrians movements through the TPAR using Flaggers, other TCM, or as directed. When the existing shoulder is greater than or equal to 4' wide, provide a minimum of 4' of width for the TPAR.

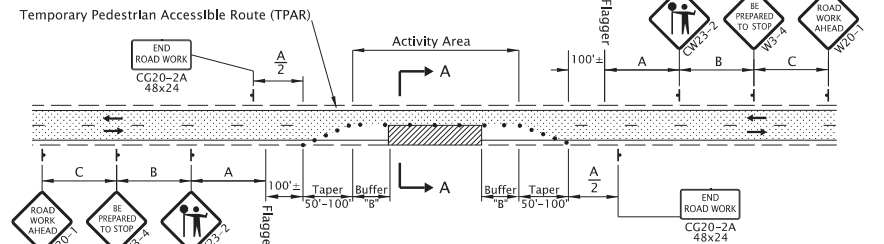

2-Lane, 2-Way Roadway
ONE LANE CLOSURE

- GENERAL NOTES FOR ALL DETAILS:
- The "FLAGGER" (CW23-2) symbol sign shall be used only in conjunction with the "BE PREPARED TO STOP" (W3-4) sign.
 - Cover existing passing zone signing, as directed.
 - Install temporary striping as required.
 - To determine Taper Length ("L") and Buffer Length ("B"), use the "MINIMUM LENGTHS TABLE" shown on Dwg. No. TM800.
 - To determine sign spacing A, B, and C, use "TRAFFIC CONTROL DEVICES (TCD) SPACING TABLE" on Dwg. No. TM800.
 - Install a "BICYCLES ON ROADWAY" (CW11-1) sign in advance of the closure when a bike lane is closed, or when the shoulder is closed and bikes are expected.
 - At night, flagger stations shall be illuminated according to the FLAGGER STATION LIGHTING DELINEATION detail on Dwg No. TM800.
 - To be accompanied by Dwg. Nos. TM820 & TM821.
 - 28" Tubular Markers on 20' max. spacing for flagger tapers and stations.
 - 28" Tubular Markers See TCD Spacing Table on TM800 for max. spacing.
-

- NOTE:
- Use a minimum of 3 tubular markers in shoulder taper on 10' spacing for flagger station delineation.

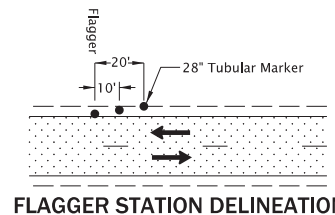

FLAGGER STATION DELINEATION

CALC. BOOK NO. --- N/A ---	SDR DATE --- 01-JUL-2020 ---
NOTE: All material and workmanship shall be in accordance with the current Oregon Standard Specifications	
OREGON STANDARD DRAWINGS	
2-LANE, 2-WAY ROADWAYS	
2021	
DATE	REVISION DESCRIPTION

TM850